



ADVANCED PRESSURE TECHNOLOGY

SERIES AK 1000 SINGLE STAGE PRESSURE REGULATOR

QUALITY, RELIABILITY AND PERFORMANCE



- ◆ Vacuum to 3,500 psig (241 bar) inlet, 500 psig (35 bar) outlet
- ◆ Flow capacity*
0 to 100 slpm (0 to 3.5 scfm) HF Option
- ◆ Stainless Steel or Brass construction
- ◆ Hastelloy® C-22® Internals, 'SH' option, for added corrosion resistance
- ◆ High leak integrity
- ◆ Machined from bar stock
- ◆ Optional accessories
- ◆ Fine adjustment control
(six turns of the knob from off to wide open)
- ◆ Cleaned for O2 service
- ◆ Field repairable
- ◆ Diffusion resistant Stainless Steel diaphragm

ENGINEERING DATA

Operating Parameters

Source pressure	vacuum to 3,500 psig (241 bar) (AK1001, 300 psig [21 bar] max)
Delivery pressure	0.5 to 10 psig (0.03 to 0.7 bar) AK 1001 1 to 30 psig (0.07 to 2 bar) AK 1002 2 to 100 psig (0.14 to 7 bar) AK 1010 5 to 200 psig (0.3 to 14 bar) AK 1020 5 to 300 psig (0.3 to 21 bar) AK 1030 **10 to 500 psig (0.7 to 35 bar) AK 1050
Proof pressure	4,500 psig (307 bar)
Burst pressure	10,000 psig (690 bar)

Other Parameters

Inlet /outlet ports	1/4" NPT; 1/4" & 3/8" compression (optional porting available)
Flow coefficient, Cv	0.09 (HF option 0.15)
Internal volume	0.49 in ³ (8 cm ³)
Operating temperature	-40 to +160F (-40 to +71C)***
Leak rate	1 x 10 ⁻⁹ sccs
Delivery pressure rise	0.25 psig per 100 psig source pressure drop (HF 0.75 psi per 100 psig)

MATERIALS OF CONSTRUCTION

	AK 1000B	AK 1000S	AK 1000SH
Body	brass	SS 316	SS 316
Poppet and diaphragm	SS 316	SS 316	Hastelloy C-22
Seat	PCTFE (Vespe ^l ® and PEEK Opt)	PCTFE (Vespe ^l and PEEK Opt)	PCTFE (PEEK Opt)
Bonnet	SS 303	SS 303	SS 303

* Flow rating based upon N2 @ 100 psig inlet, varying gas type and, or inlet/outlet pressures may effect rating.
 ** AK 1050 and panel mount height dimension different
 *** Optional temperature ranges available. Please contact factory.

All specifications subject to change without notice.
 Hastelloy® C-22® Haynes Corporation
 Vespe^l® DuPont

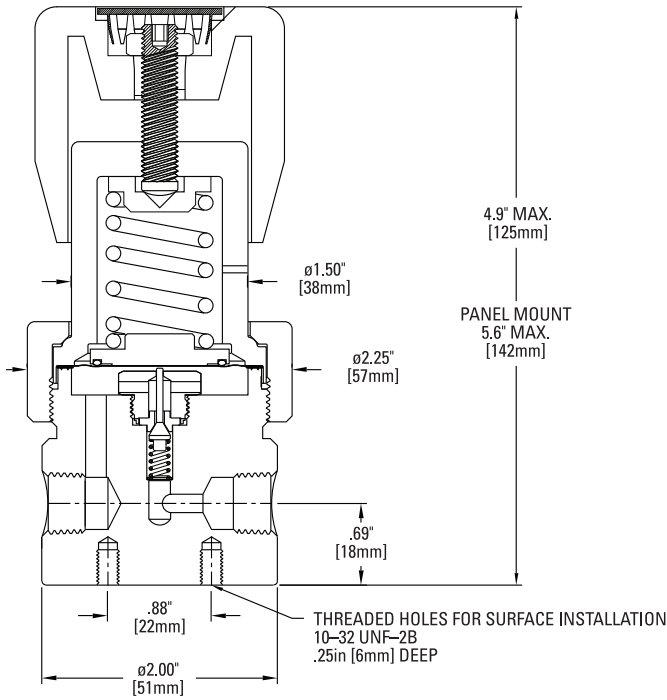

All dimensions in inches (mm).
Metric dimensions are for reference only.

Porting Configurations

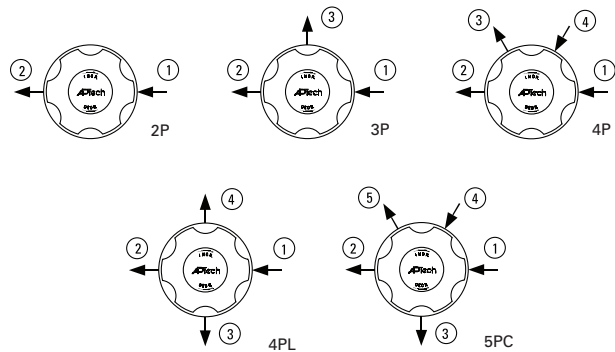

NOTE: Not all porting configurations available in brass.

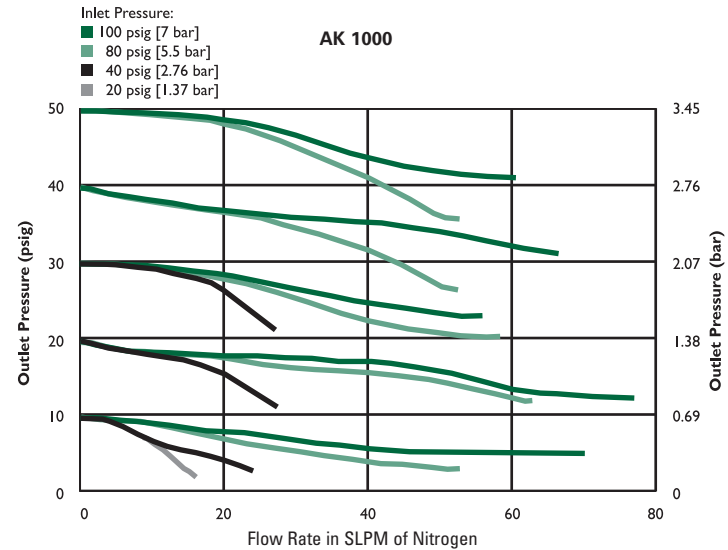
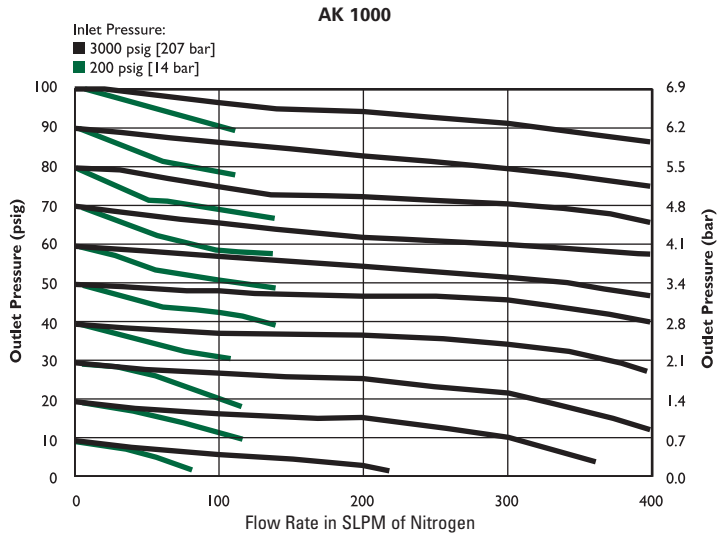

ORDERING INFORMATION

AK 1002 Series	S Material	3P Port Configuration	4 4 ① ② Ports	0 ③ ④ ⑤ Ports (Gauge/Accessory)	P Options
AK 1001= 0.5-10 psig (.03 to .7 bar)		2P = 2 Ports	4 = 1/4 inch NPT	0 = No gauge or device installed	P = Panel installation*
AK 1002= 1-30 psig (.07 to 2 bar)		3P = 3 Ports	4T = 1/4 inch compression	V3 = 30-0-30 psig/bar	CGA = Inlet fitting 320, 330, 350, 580, 660, 678
AK 1010= 2-100 psig (.14 to 7 bar)		4PL = 4 Ports	6T = 3/8 inch compression	1 = 30-0-100 psig/bar	VS = Vespel seat
AK 1020= 5-200 psig (.3 to 14 bar)		5PC = 5 Ports		2 = 0-200 psig/bar	PK = PEEK seat
AK 1030= 5-300 psig (.3 to 21 bar)				10 = 0-1000 psig/bar	HF = High flow
AK 1050= 10-500 psig (.7 to 35 bar)				40 = 0-4000 psig/bar	
S = Stainless steel (SS)					
SH = SS with Hastelloy internals					
B = Brass					

NOTE: Designators required for all ports, but "0" not required if there isn't a port. A 2P has designators only for ① & ② ports, as example AK 1010 S 2P 44 not AK 1010 S 2P 44 000.

*Panel hole 1.42 diameter