



SERIES AP 1200

TIED DIAPHRAGM REGULATOR

High Performance — High Flow – High Pressure

- Single stage
- Stainless steel 316L VAR secondary remelt construction
- Flow rates
 - standard to 800 slpm (28 scfm)
 - HF option to 1,000 slpm (35 scfm)
 - FC option to 1,500 slpm (52 scfm)
- Vacuum to 1,700 psig (117 bar) inlet
 - FC Option – vacuum to 300 psig (21 bar) inlet
 - HR Option – vacuum to 3,000 psig (207 bar) inlet
- Point of use and source cylinder applications
- Installation and operating instructions available at www.aptech-online.com in the Tech Briefs section

Operating Parameters

Source pressure	AP 1200	vacuum to 1,700 psig (117 bar)
	AP 1200 HF	vacuum to 1,700 psig (117 bar)
	AP 1215	vacuum to 1000 psig (69 bar)
	AP 1200 FC	vacuum to 300 psig (21 bar)
	AP 1200 HR	vacuum to 3,000 psig (207 bar)***
Delivery pressure	AP 1202	1 to 30 psig (0.07 to 2 bar) (not available for FC or HR)
	AP 1206	1 to 60 psig (0.07 to 4 bar) (not available for FC or HR)
	AP 1210	2 to 100 psig (0.14 to 7 bar)
	AP 1215	5 to 150 psig (.34 to 10 bar)
	AP 1225*	Preset to 250 psig (17 bar) at 800 psig Inlet (not available for HR or FC)
Proof pressure		2,550 psig (176 bar); HR option 4,500 psig (310 bar)
Burst pressure		8,000 psig (552 bar); HR option 9,000 psig (620 bar)

* Custom inlet/outlet pressure settings available—contact factory

Other Parameters

Inlet/outlet connectors	1/4, 3/8, 1/2, 3/4 inch face seal or tube weld
Bonnet port	1/8 inch NPT
Flow coefficient (Cv)	0.9 (HF = 1.1 and FC = 0.65)
Internal volume	1.07 in ³ (17.6 cm ³)
Operating temperature	-40° to +160°F (-40° to +71°C)
Surface finish	15 µin. (0.4 µm) Ra max standard; 10 µin (0.25 µm); 7 µin (0.18 µm); and 5 µin (0.13 µm) optional
Inboard leakage	2 x 10 ⁻¹⁰ sccs
Outboard leakage	2 x 10 ⁻⁹ sccs He at 1,500 psig inlet pressure
Leakage across seat	4 x 10 ⁻⁸ sccs He at 1,000 psig inlet pressure
Installation	surface or panel (optional)
Delivery pressure rise	3.5 psig per 100 psig source pressure drop
	HF & FC 4.2 psig per 100 psig source pressure drop

Materials

	Series AP 1200 S Noncorrosive	Series AP 1200 SH Corrosive (SHP** opt)
Type of Service		
Wetted Parts		
Body	SS 316L secondary remelt	SS 316L secondary remelt
Poppet, nozzle	SS 316L	Hastelloy® C-22®
Diaphragm	Hastelloy C-22	Hastelloy C-22
Finish	electropolished and passivated	electropolished and passivated
Seat	PCTFE (VespeI® optional)	PCTFE

All specifications subject to change without notice.

** SHP option Hastelloy poppet and diaphragm only.

***3/4 inch face seal fittings rated to 2,400 psig (165 bar) maximum

Hastelloy® C-22® Haynes Corporation VespeI® DuPont

SERVICE AND SUPPORT BEYOND COMPARE

DIMENSIONAL INFORMATION

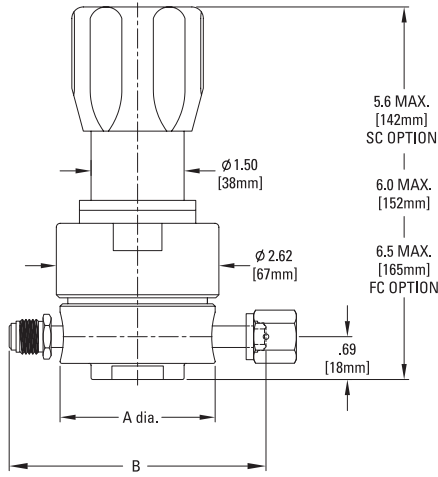

Face Seal	A	B
1/4" Male	2.00" (51 mm)	4.00" ±.02 (102 mm)
1/4" Female	2.00" (51 mm)	3.70" ±.02 (94 mm)
3/8"	2.50" (64 mm)	5.22" ±.03 (133 mm)
1/2"	2.50" (64 mm)	5.22" ±.03 (133 mm)
3/4"	2.50" (64 mm)	6.26" ±.04 (159 mm)

All dimensions in inches (mm). Metric dimensions are for reference only.

PORTING CONFIGURATIONS

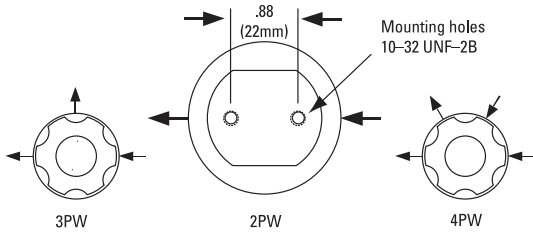

CAUTION: Product selection is the sole responsibility of the user, regardless of any recommendations or suggestions made by the factory. The user shall make selections based upon their own analysis and testing with regard to function, material compatibility and product ratings. Proper installation, operation and maintenance are also required to assure safe, trouble free performance.

ORDERING INFORMATION

Sample Order Number

AP 1210SM 3PW FV8 FV8 1 FC

AP 1210 | Series

AP 1202 = 1-30 psig (0.07 to 2 bar)
 AP 1206 = 2-60 psig (.14 to 4 bar)
 AP 1210 = 2-100 psig (.14 to 7 bar)
 AP 1215 = 5-150 psig (.34 to 10 bar)
 AP 1225 = 250 psig (17 bar) Preset

S | Material

S = Stainless steel (SS)
 SH = SS/Hastelloy internals
 SHP = SS/Hastelloy poppet and diaphragm

M | Surface Finish Options

M = 10 μin. Ra max
 V = 7 μin. Ra max
 X = 5 μin. Ra max

3PW | Ports

2PW = 2 ports butt weld face seal
 3PW = 3 ports butt weld face seal
 4PW = 4 ports butt weld face seal

FV8 FV8 | Connections Inlet / Outlet

Tube weld stub available.
 "FC" option only available with 1/2" or 3/4" connectors.

*3/4 inch face seal fittings rated to 2,400 psig (165 bar) maximum.

1 | Gauges Source / Delivery

Standard gauge ports are 1/4 inch face seal male.

(1/4 inch face seal female are available).

FC | Options

**HR, HF and FC options are only available separately. These options may not be combined.

FV4 = 1/4 inch face seal female
 MV4 = 1/4 inch face seal male
 FV6 = 3/8 inch face seal female
 MV6 = 3/8 inch face seal male
 FV8 = 1/2 inch face seal female
 MV8 = 1/2 inch face seal male
 FV12 = 3/4 inch face seal female*
 MV12 = 3/4 inch face seal male*

0 = No gauge
 V3 = 30-0-30 psig/bar
 L = 30-0-60 psig/bar
 1 = 30-0-100 psig/bar
 2 = 0-200 psig/bar
 4 = 0-400 psig/bar
 10 = 0-1000 psig/bar
 40 = 0-4000 psig/bar
 H = 30-0-160 psig/bar

HR = High Inlet Pressure**
 HF = High Flow**
 FC = Force Compensation**
 P = Panel installation ring
 VS = Vespel seat
 SC = Short, single piece bonnet

