



# SERIES AP 1400T

## TIED DIAPHRAGM REGULATOR

Intermediate to high flow applications

- Single stage
- Stainless steel 316L VAR secondary remelt construction
- Absolute sub-atmospheric option, flow rate to 6 slpm
- Cylinder or point of use specialty and bulk gases
- Flow rates to 600 slpm (21 scfm)
- Vacuum to 2,300 psig (159 bar) inlet
- Designed and manufactured exclusively for UHP semiconductor applications
- Installation and operating instructions available at [www.aptech-online.com](http://www.aptech-online.com) in the Tech Briefs section

### Operating Parameters

Source pressure	AP 1400T	vacuum to 2,300 psig (159 bar)
	AP 1415T	vacuum 1,000 psig (69 bar)
	AP 1400TA	vacuum to 300 psig (21 bar)
	AP 1400T HR	vacuum to 3,000 psig (207 bar)
Delivery pressure	AP 1402TA	100 mm Hg absolute to 30 psig (2 bar) <i>(not available for HR)</i>
	AP 1402T	1 to 30 psig (0.07 to 2 bar) <i>(not available for HR)</i>
	AP 1406T	1 to 60 psig (0.07 to 4 bar) <i>(not available for HR)</i>
	AP 1410T	2 to 100 psig (0.14 to 7 bar)
	AP 1415T	5 to 150 psig (.34 to 10 bar)
Proof pressure		4,000 psig (276 bar); HR option 4,500 psig (310 bar)
Burst pressure		8,000 psig (552 bar); HR option 9,000 psig (620 bar)

### Other Parameters

Inlet/outlet connectors	1/4, 3/8 or 1/2 inch face seal or tube weld
Bonnet port	1/8 inch NPT
Flow coefficient (Cv)	0.45
Internal volume	1.06 in <sup>3</sup> (17.4 cm <sup>3</sup> )
Operating temperature	-40° to +160°F (-40° to +71°C)
Surface finish	15 µin. (0.4 µm) Ra max standard; 10 µin (0.25 µm); 7 µin (0.18 µm); and 5 µin (0.13 µm) optional
Inboard leakage	2 x 10 <sup>-10</sup> sccs
Outboard leakage	2 x 10 <sup>-9</sup> sccs He at 1,500 psig inlet pressure
Leakage across seat	4 x 10 <sup>-8</sup> sccs He at 1,000 psig inlet pressure
Installation	surface or panel (optional)
Delivery pressure rise	1.6 psig per 100 psig source pressure drop

### Materials

Type of Service	Series AP 1400T S	Series AP 1400T SH
Wetted Parts	Corrosive	Corrosive
Body	SS 316L secondary remelt	SS 316L secondary remelt
Poppet and diaphragm	Hastelloy® C-22®	Hastelloy C-22
Nozzle	SS 316L	Hastelloy C-22
Finish	electropolished and passivated	electropolished and passivated
Seat	PCTFE (Vespe® optional)	PCTFE

All specifications subject to change without notice.

Hastelloy® C-22® Haynes Corporation

Vespe® DuPont

# ULTRACLEAN BY DESIGN

## DIMENSIONAL INFORMATION

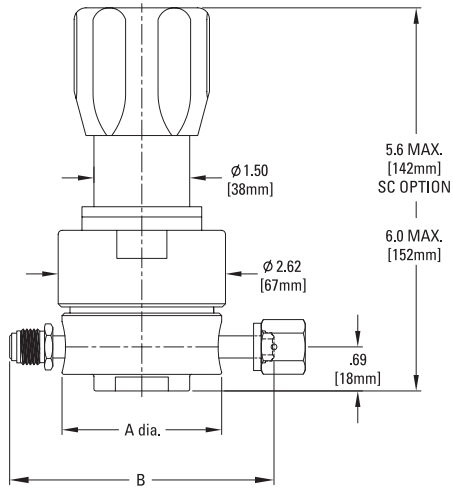

Face Seal	A	B
1/4" Male	2.00" (51 mm)	4.00" ±.02 (102 mm)
1/4" Female	2.00" (51 mm)	3.70" ±.02 (94 mm)
3/8"	2.50" (64 mm)	5.22" ±.03 (133 mm)
1/2"	2.50" (64 mm)	5.22" ±.03 (133 mm)

All dimensions in inches (mm). Metric dimensions are for reference only.

## PORTING CONFIGURATIONS

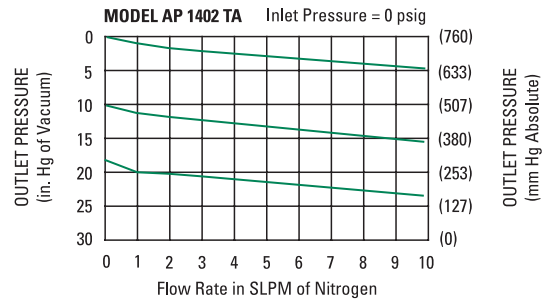
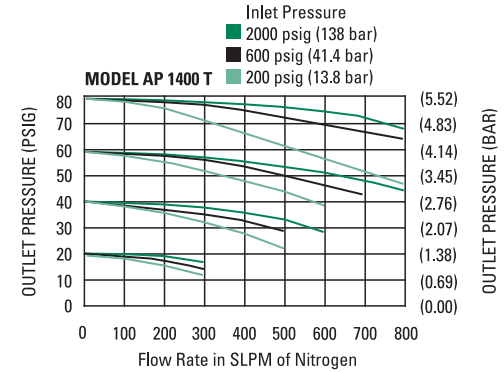
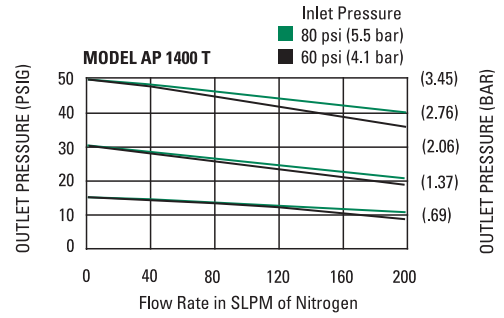
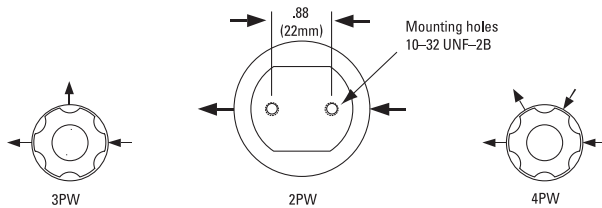

**CAUTION: Product selection is the sole responsibility of the user, regardless of any recommendations or suggestions made by the factory. The user shall make selections based upon their own analysis and testing with regard to function, material compatibility and product ratings. Proper installation, operation and maintenance are also required to assure safe, trouble free performance.**

## ORDERING INFORMATION

Sample Order Number **AP 1402T SMA 3PW FV4 FV4 V3**

<b>AP 1402T   Series</b>	AP 1402T = 1-30 psig (.07 to 2 bar) AP 1406T = 1-60 psig (.07 to 4 bar) AP 1410T = 2-100 psig (.14 to 7 bar)
<b>S   Material</b>	S = Stainless steel (SHP)* SH = SS/Hastelloy internals
<b>M   Surface Finish Options</b>	M = 10 μin. Ra max V = 7 μin. Ra max X = 5 μin. Ra max
<b>A   Range Options</b>	A = 100 mm Hg absolute to 30 psig (2 bar) (AP 1402T option only)
<b>3PW   Ports</b>	2PW = 2 ports butt weld face seal 3PW = 3 ports butt weld face seal 4PW = 4 ports butt weld face seal

### FV4 FV4 | Connections Inlet / Outlet

- FV4 = 1/4 inch face seal female
- MV4 = 1/4 inch face seal male
- FV6 = 3/8 inch face seal female
- MV6 = 3/8 inch face seal male
- FV8 = 1/2 inch face seal female
- MV8 = 1/2 inch face seal male

Tube weld stub available

### V3 | Gauges Source / Delivery

Standard gauge ports are 1/4 inch face seal male.  
(1/4 inch face seal female are available).

- 0 = No gauge
- V3 = 30-0-30 psig/bar
- L = 30-0-60 psig/bar
- 1 = 30-0-100 psig/bar
- 2 = 0-200 psig/bar
- 4 = 0-400 psig/bar
- 10 = 0-1000 psig/bar
- 40 = 0-4000 psig/bar

### Options

On panel mount option, bonnet port is not threaded. Panel hole 1.56" diameter.

- P = Panel installation ring
- VS = Vespel seat
- HR = High inlet pressure
- SC = Short, single piece bonnet

\*S equivalent to SHP – stainless steel with Hastelloy poppet and diaphragm