



# SERIES AP 2700

## TWO-STAGE, TIED DIAPHRAGM REGULATOR

High Flow — High Inlet Pressure

- Regulator of choice for NF<sub>3</sub> and H<sub>2</sub> BSGS delivery of intermediate flows
- Flow rates to 150 slpm of NF<sub>3</sub> and 900 slpm of H<sub>2</sub> (based upon minimum inlet pressure of 200 psig (14 bar))
- 15 μin. surface finish (10, 7 and 5 μin. opt)
- Vacuum to 3,500 psig (241 bar) inlet
- Cleaned, assembled and packaged for high purity semiconductor applications
- Two stage pressure reduction eliminates supply pressure effect

### Operating Parameters

Source pressure	vacuum to 3,500 psig (241 bar)
Delivery pressure	AP 2702 1 to 30 psig (0.07 to 2 bar)
	AP 2706 2 to 60 psig (0.14 to 4 bar)
	AP 2710 2 to 100 psig (0.14 to 7 bar)
	AP 2712 3 to 120 psig (0.21 to 8 bar)
First stage pressure	200 psig (14 bar) nominal
Proof pressure	4,000 psig (276 bar)
Burst pressure	8,000 psig (552 bar)

### Other Parameters

Inlet/outlet connectors	1/4 or 3/8 inch face seal or tube weld
Bonnet port	1/8 inch NPT
Flow coefficient (Cv)	0.105
Internal volume	1.87 in <sup>3</sup> (30.6 cm <sup>3</sup> )
Operating temperature	-40° to +160°F (-40° to +71°C)
Surface finish	15 μin. (0.4 μm) Ra max standard; 10 μin (0.25 μm); 7 μin (0.18 μm); and 5 μin (0.13 μm) optional
Inboard leakage	2 x 10 <sup>-10</sup> sccs
Outboard leakage	2 x 10 <sup>-9</sup> sccs He at 1,500 psig inlet pressure
Leakage across seat	4 x 10 <sup>-8</sup> sccs He at 1,000 psig inlet pressure
Installation	panel (optional)
Delivery pressure decrease	0.01 psig per 100 psig source pressure drop

### Materials

	Series AP 2700 S Noncorrosive	Series AP 2700 SH Corrosive
Type of Service Wetted Parts		
Body	SS 316L secondary remelt	SS 316L secondary remelt
Poppet, nozzle and diaphragm	SS 316L/Hastelloy® alloy C-22®	Hastelloy® alloy C-22®
Finish	electropolished and passivated	electropolished and passivated
Seat	PCTFE (VespeI® optional)	PCTFE

All specifications subject to change without notice.

Hastelloy® C-22® Haynes Corporation VespeI® DuPont

Note: AP Tech recommends monitoring the intermediate pressure (first stage outlet/second stage inlet) for safety. Please refer to product note 409 for further information.

# SERVICE AND SUPPORT BEYOND COMPARE

## DIMENSIONAL INFORMATION

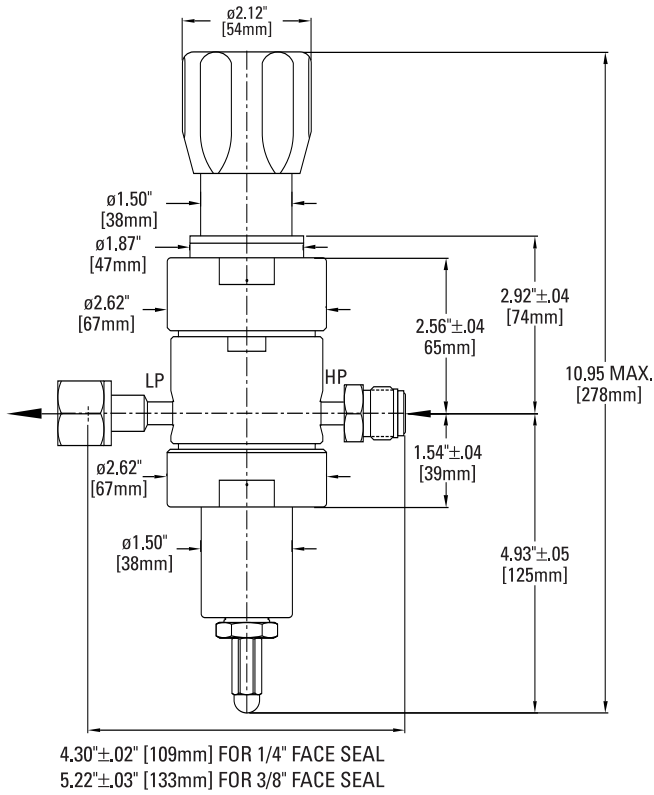

## PORTING CONFIGURATIONS

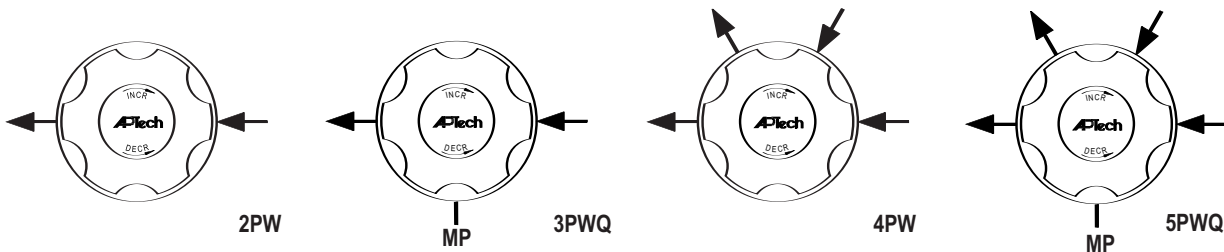

All dimensions in inches (mm). Metric dimensions are for reference only.  
 MP=Monitor port, first stage outlet pressure (second stage inlet pressure)

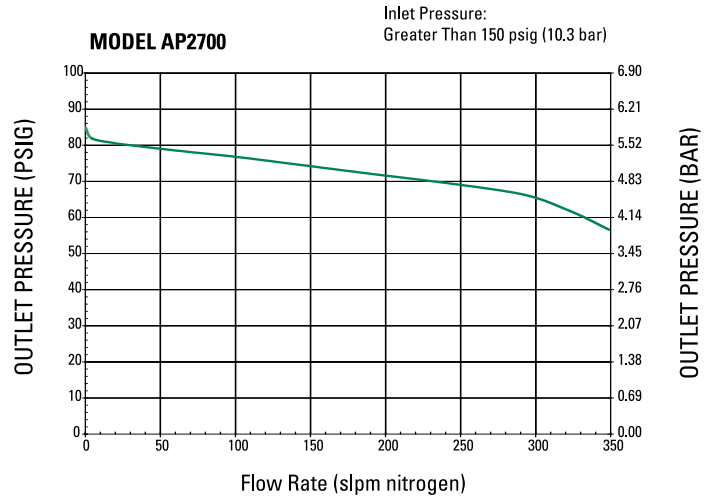

Note: APTech recommends MP port to enable monitoring of intermediate pressure. Please refer to product note 409 for further information.

## ORDERING INFORMATION

Sample Order Number **AP 2702SM 5PWQ FV4 FV4 40 V3**

**AP 2702 | Series**  
 AP 2702 = 1-30 psig (0.07 to 2 bar)  
 AP 2706 = 2-60 psig (0.14 to 4 bar)  
 AP 2710 = 2-100 psig (0.14 to 7 bar)  
 AP 2712 = 3-120 psig (0.21 to 8 bar)

**S | Material**  
 S = Stainless steel (SS)  
 SH = SS with Hastelloy internals

**M | Surface Finish Options**  
 M = 10  $\mu$ m. Ra max  
 V = 7  $\mu$ m. Ra max  
 X = 5  $\mu$ m. Ra max

**5PWQ | Ports**  
 2PW = 2 ports butt weld  
 3PWQ = 3 ports butt weld  
 4PW = 4 ports butt weld  
 5PWQ = 5 ports butt weld

**FV4 FV4 | Connections Inlet / Outlet**  
 FV4 = 1/4 inch face seal female  
 MV4 = 1/4 inch face seal male  
 FV6 = 3/8 inch face seal female  
 MV6 = 3/8 inch face seal male

Tube weld stub available

**40 V3 | Gauges\* Source / Delivery**  
 0 = No gauge  
 V3 = 30-0-30 psig/bar  
 L = 30-0-60 psig/bar  
 1 = 30-0-100 psig/bar  
 2 = 0-200 psig/bar  
 10 = 0-1000 psig/bar  
 40 = 0-4000 psig/bar

\* Standard gauge and MP ports are 1/4 inch face seal male (1/4 inch face seal female are available).

**Options**  
 P = Panel installation ring\*\*  
 VS = Vespel seat

\*\* On panel mount option, bonnet port is not threaded. Panel hole 1.56" diameter.