



SERIES AP 3000

AIR ACTUATED NC 1/4 INCH DIAPHRAGM VALVE

High pressure rated

- Stainless steel 316L VAR secondary remelt or Hastelloy® alloy C-22® construction
- 15 µin. surface finish (10, 7 and 5 µin. opt)
- Metal to metal seal to atmosphere
- Replaceable PCTFE seat (Vespel® optional)
- Pneumatically actuated normally closed (NC)
- Vacuum to 3,000 psig (207 bar)
- Multiport and monoblock configurations
- LOTO option — PL210

Operating Parameters

Inlet pressure	vacuum to 3,000 psig (207 bar)
Outlet pressure	vacuum to inlet pressure
Proof pressure	4,000 psig (276 bar)
Burst pressure	8,000 psig (552 bar)
Actuation pressure	70 to 110 psig (4.8 to 7.6 bar)

Other Parameters

Status	normally closed
Inlet/outlet connectors	1/4 or 3/8 inch face seal or tube weld
Actuation port	1/8 inch NPT, top port
Flow coefficient (Cv) 3000	0.23, X _T = 0.5
3002	0.28, X _T = 0.5
Internal volume	0.06 in ³ (1.07 cm ³)
Operating temperature	-40° to +160°F (-40° to +71°C)
Surface finish	15 µin. (0.4 µm) Ra max standard; 10 µin (0.25 µm); 7 µin (0.18 µm); and 5 µin (0.13 µm) optional
Inboard leakage	2 x 10 ⁻¹⁰ sccs
Outboard leakage	2 x 10 ⁻⁹ sccs He at 1,000 psig
Leakage across seat	4 x 10 ⁻⁸ sccs He at 1,000 psig inlet pressure

Materials

	Series AP 3000 S Noncorrosive	Series AP 3000 H Corrosive
Type of Service		
Wetted Parts		
Body	SS 316L secondary remelt	Hastelloy alloy C-22
Finish	electropolished and passivated	electropolished
Diaphragm	Elgiloy®	Elgiloy
Seat	PCTFE (Vespel® optional)	PCTFE

All specifications subject to change without notice.

Hastelloy® C-22® Haynes Corporation Vespel® DuPont Elgiloy® Elgiloy Corporation

THE ULTIMATE IN ULTRACLEAN

DIMENSIONAL INFORMATION

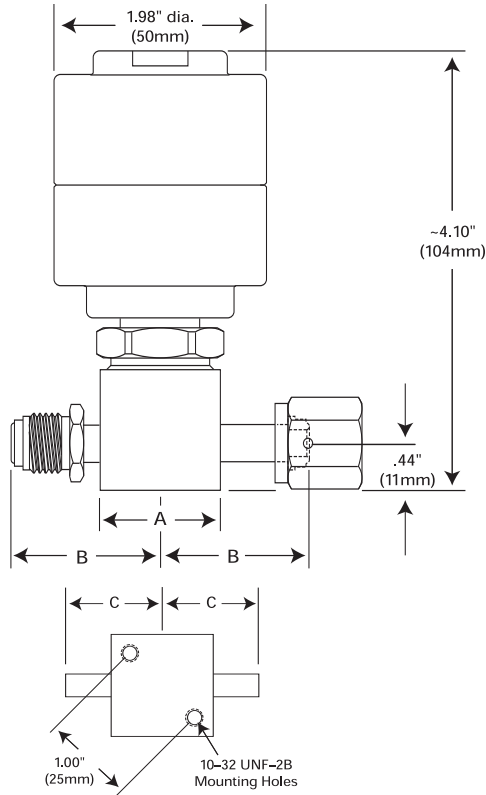

PORTING CONFIGURATIONS

Please refer to Technical Bulletin 203 for valve porting configurations.

Hastelloy design may vary. Please consult factory for current specifications.

MATERIAL	CONNECTION	A		B		C	
		in.	mm	in. [± 0.01]	mm	in. [± 0.01]	mm
S	FV4, MV4	1.12 sq.	28	1.39	35	–	–
	TW4	1.12 sq.	28	–	–	1.06	27
	FV6, MV6	1.12 sq.	28	1.93	49	–	–
	TW6	1.12 sq.	28	–	–	1.33	34
H	FV4, MV4	1.25 dia.	32	1.45	37	–	–
	TW4	1.25 dia.	32	–	–	1.08	27
	FV6, MV6	1.25 dia.	32	1.93	49	–	–
	TW6	1.25 dia.	32	–	–	1.33	34

All dimensions in inches (mm). Metric dimensions are for reference only.

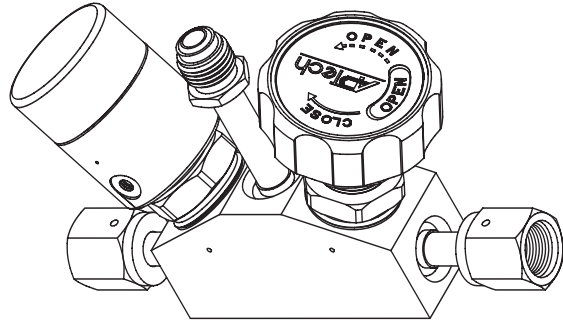

Multiport, monoblock, IGS and custom configurations available.

ORDERING INFORMATION

Sample Order Number

AP 3000SM 2PW MV4 MV4 VS

AP 3000 | Series

AP 3000
AP 3002*

* AP 3002 has higher Cv

S | Material

S = Stainless steel (SS)
H = Hastelloy alloy C-22

M | Surface Finish Options

M = 10 μ m. Ra max
V = 7 μ m. Ra max
X = 5 μ m. Ra max

2PW | Ports

2PW = 2 ports
3PW = 3 ports
4PW = 4 ports
5PW = 5 ports

Refer to valve porting guide for selection

MV4 MV4 | Connections Inlet / Outlet

FV4 = 1/4 inch face seal female
MV4 = 1/4 inch face seal male
TW4 = 1/4 inch tube stub weld

(3/8 connectors optional)

VS | Options

1.75 = 1.75" face to face TW4
VS = Vespel seat
IS = Indicator Switch