



SERIES AP 3700 & 3708

AIR ACTUATED 1/2" SPRINGLESS DIAPHRAGM VALVE

Defining new levels of ultraclean

- Normally closed, AP 3700
Normally open, AP 3708
- Vacuum to 250 psig (17 bar)
- Multiport and monoblock integrated components
- Stainless steel 316L VAR secondary remelt construction
- Cleaned, assembled and tested for UHP semiconductor applications
- Metal to metal diaphragm seal to atmosphere
- Machined from bar stock
- Installation and operating instructions available at www.aptech-online.com in the Tech Briefs section

Operating Parameters — all valves

| | |
|--------------------|-------------------------------|
| Inlet pressure | vacuum to 250 psig (17 bar) |
| Outlet pressure | vacuum to inlet pressure |
| Proof pressure | 500 psig (34 bar) |
| Burst pressure | 1,000 psig (69 bar) |
| Actuation pressure | 80 to 100 psig (5.5 to 7 bar) |

Other Parameters — all valves

| | | |
|--------------------------|--------------------|---|
| Status | AP 3700 AP 3708 | normally closed (NC) normally open (NO) |
| Inlet /outlet connectors | | 3/8, 1/2 or 3/4 inch face seal or tube weld |
| Actuation port | | #10–32 thread, side port |
| Flow coefficient (Cv) | | 2.8, X _T = 1.0 |
| Internal volume | | 0.76 in ³ (12.52 cm ³) |
| Operating temperature | | -40° to +160°F (-40° to +71°C) |
| Surface finish | | 10 μin. (0.25 μm) Ra max standard; 7 μin (0.18 μm); and 5 μin (0.13 μm) optional |
| Inboard leakage | | 2 x 10 ⁻¹⁰ sccs |
| Outboard leakage | | 2 x 10 ⁻⁹ sccs He at 125 psig |
| Leakage across seat | | 4 x 10 ⁻⁸ sccs He at 125 psig inlet pressure |

Materials

| | Series AP 3700 |
|--------------|--------------------------------|
| Wetted Parts | |
| Body | SS 316L secondary remelt |
| Finish | electropolished and passivated |
| Diaphragm | SS 316L |
| Seat | PCTFE® (Vespel optional) |

All specifications subject to change without notice

Vespel® DuPont

ENGINEERING DATA — SERIES AP 3700 AIR ACTUATED 1/2" SPRINGLESS DIAPHRAGM VALVE

UNCOMPROMISING QUALITY, PERFORMANCE AND RELIABILITY

DIMENSIONAL INFORMATION

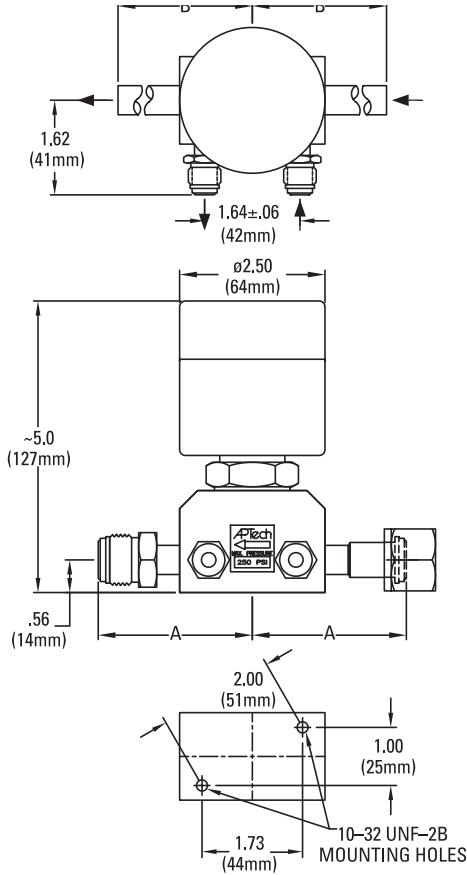

| Connection | A | | B | |
|----------------|------------|----|------------|-----|
| | in. [±.02] | mm | in. [±.02] | mm |
| FV8, MV8 | 2.65 | 67 | — | — |
| TW6, TW8, TW12 | — | — | 4.25 | 108 |
| FV12, MV12 | 3.20 | 81 | — | — |

All dimensions in inches (mm). Metric dimensions are for reference only.

PORTING CONFIGURATIONS

Please refer to Technical Bulletin 204 for multiport and monoblock configurations.

CAUTION: Product selection is the sole responsibility of the user, regardless of any recommendations or suggestions made by the factory. The user shall make selections based upon their own analysis and testing with regard to function, material compatibility and product ratings. Proper installation, operation and maintenance are also required to assure safe, trouble free performance.

ORDERING INFORMATION

Sample Order Number **AP 3700SM TW8 TW8 0B C**

AP 3700 | Series

AP 3700
AP 3708

S | Material

S = Stainless steel (SS)

M | Surface Finish Options

M = 10 μ m. Ra max
V = 7 μ m. Ra max
X = 5 μ m. Ra max

TW8 TW8 | Connections Inlet / Outlet

TW6 = 3/8 inch tube stub weld
FV8 = 1/2 inch face seal female
MV8 = 1/2 inch face seal male
TW8 = 1/2 inch tube stub weld
FV12 = 3/4 inch face seal female
MV12 = 3/4 inch face seal male
TW12 = 3/4 inch tube stub weld

0B | Purge Port Inlet / Outlet

M = Inlet purge port (main)
B = Outlet purge port (branch)
0 = No purge port

C | Options

ISC = Indicator Switch, NC (3700 only)
ISO = Indicator Switch, NO (3700 only)
VS = Vespel Seat
C = Capped Purge Port