



SERIES AP 500

MINI REGULATOR

Ultra Compact / Ultra Clean

- Single stage
- Stainless steel 316L VAR secondary remelt construction
- Compact size with low internal volume
- High performance with low hysteresis
- Vacuum to 150 psig (10 bar) inlet
- Surface mount (IGS) configurations
- 15 slpm flow capacity HF option to 30 slpm
- Sub-atmospheric to low positive pressure delivery
- Installation and operating instructions available at www.aptech-online.com in the Tech Briefs section

Operating Parameters

Source pressure	vacuum to 150 psig (10 bar)
Delivery pressure	AP 501A 100 mm Hg absolute to 10 psig (0.7 bar)
	AP 502 0.5 to 30 psig (0.034 to 2 bar)
	AP 510 1 to 100 psig (0.07 to 7 bar)
Proof pressure	500 psig (34 bar)
Burst pressure	1,000 psig (69 bar)

Other Parameters

Inlet/outlet connectors	1/4 or 3/8 inch face seal or tube weld
Flow coefficient (Cv)	0.06 (0.1 HF option)
Internal volume	0.15 in ³ (2.4 cm ³)
Operating temperature	-40° to +160°F (-40° to +71°C)
Surface finish	15 μin. (0.4 μm) Ra max standard; 10 μin (0.25 μm); 7 μin (0.18 μm); and 5 μin (0.13 μm) optional
Inboard leakage	2 x 10 ⁻¹⁰ sccs
Outboard leakage	2 x 10 ⁻⁹ sccs He at 100 psig inlet pressure
Leakage across seat	4 x 10 ⁻⁸ sccs He at 100 psig inlet pressure
Delivery pressure rise	0.20 psig per 20 psig source pressure drop (0.4 psig per 20 psig source pressure drop HF option)
Installation	Surface

Materials

	Series AP 500 S	Series AP 500 SH
Type of Service	Noncorrosive	Corrosive
Wetted Parts		
Body	SS 316L secondary remelt	SS 316L secondary remelt
Poppet/diaphragm	SS 316L / Elgiloy®	Hastelloy® alloy C-22® / Elgiloy
Finish	electropolished and passivated	electropolished and passivated
Seat	PCTFE (VespeI® and PTFE optional)	PCTFE (PTFE optional)

All specifications subject to change without notice.

VespeI® DuPont Elgiloy® Elgiloy Corporation Hastelloy® C-22® Haynes Corporation

ENGINEERING DATA — SERIES AP 500 MINI REGULATOR

SERVICE AND SUPPORT BEYOND COMPARE

DIMENSIONAL INFORMATION

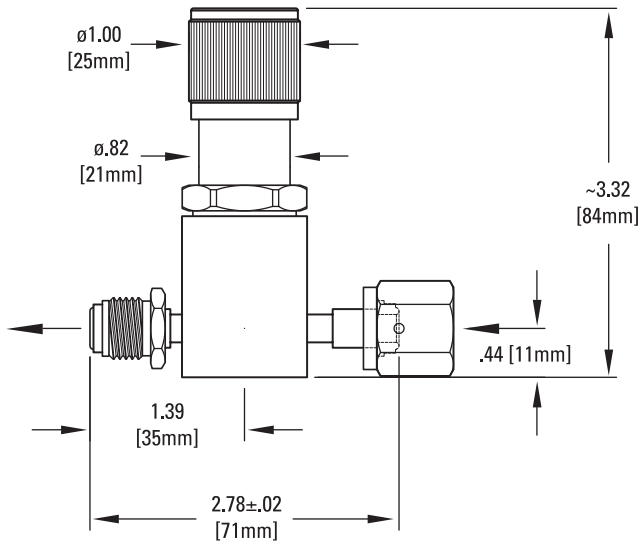

All dimensions in inches (mm). Metric dimensions are for reference only.

PORTING CONFIGURATIONS

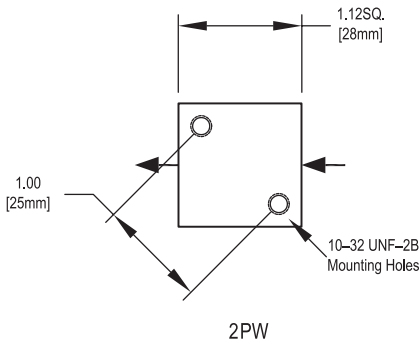

CAUTION: Product selection is the sole responsibility of the user, regardless of any recommendations or suggestions made by the factory. The user shall make selections based upon their own analysis and testing with regard to function, material compatibility and product ratings. Proper installation, operation and maintenance are also required to assure safe, trouble free performance.

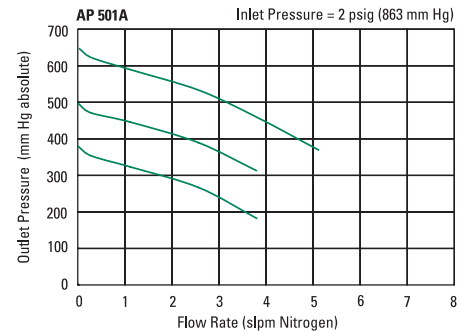
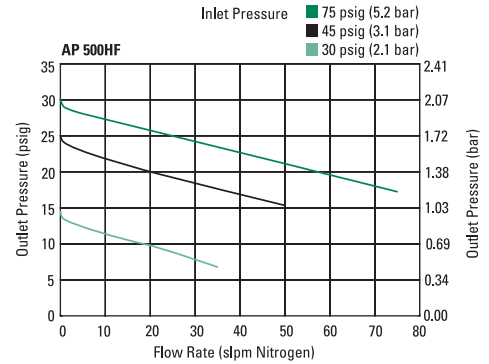
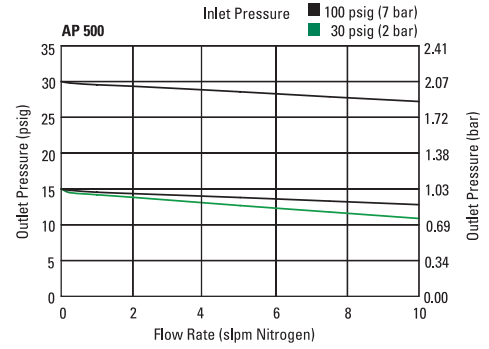

ORDERING INFORMATION

Sample Order Number	AP 502SM 2PW FV4 FV4	
AP 502 Series	AP 501 = .5-10 psig (0.034 to 0.7 bar) AP 502 = .5-30 psig (0.034 to 2 bar) AP 510 = 1-100 psig (0.07 to 7 bar)	FV4 FV4 Connections Inlet / Outlet FV4 = 1/4 inch face seal female MV4 = 1/4 inch face seal male 3/8" connections or tube weld available
S Material	S = Stainless steel (SS) SH = SS / Hastelloy internals	 Options VS = Vespel seat* HF = High flow* TF = PTFE seat *HF option not available with VS option
M Surface Finish Options	M = 10 μin. Ra max V = 7 μin. Ra max X = 5 μin. Ra max	
 Range Options	A = 100 mm Hg absolute to 10 psig (AP 501 only)	
2PW Ports	2PW = 2 ports Consult factory for other porting options or Technical Bulletin 206 for 1.125 inch C-seal surface mount (IGS) options	