



# SERIES AZ 1200

## SINGLE STAGE REGULATOR

Flow Rates to 1,500 SLPM (52 scfm)

- SS 316L construction
- High performance
- 10 µin. surface finish (25 µin. optional)
- High flow with low particle generation
- Flow rates
  - standard to 800 slpm (28 scfm)
  - HF option to 1,000 slpm (35 scfm)
  - FC option to 1,500 slpm (52 scfm)
- Point of use or cylinder specialty and bulk gases
- Vacuum to 1,700 psig (117 bar) inlet  
FC Option – vacuum to 300 psig (21 bar)  
HR Option – vacuum to 3,000 psig (207 bar)
- Installation and operating instructions available at [www.aptech-online.com](http://www.aptech-online.com) in the Tech Briefs section

### Operating Parameters

Source pressure	AZ 1200	vacuum to 1,700 psig (117 bar)
	AZ 1215	vacuum to 1,000 psig (69 bar)
	AZ 1200 HR	vacuum to 3,000 psig (207 bar)
	AZ 1200 FC	vacuum to 300 psig (21 bar)
Delivery pressure	AZ 1202	1 to 30 psig (0.07 to 2 bar) (not available for FC or HR)
	AZ 1206	2 to 60 psig (0.14 to 4 bar) (not available for FC or HR)
	AZ 1210	2 to 100 psig (0.14 to 7 bar)
	AZ 1215	5 to 150 psig (0.34 to 10 bar)
Proof pressure		2,550 psig (176 bar); HR option 4,500 psig (310 bar)
Burst pressure		8,000 psig (552 bar); HR option 9,000 psig (620 bar)

### Other Parameters

Inlet/outlet connectors	1/4, 3/8, 1/2 inch face seal or tube weld
Flow coefficient (Cv)	0.9 (FC = 0.65, HF = 1.1)
Internal volume	1.07 in <sup>3</sup> (17.6 cm <sup>3</sup> )
Operating temperature	-40° to +160°F (-40° to +71°C)
Surface finish	10 µin. (0.25 µm) Ra avg. 25 µin. (0.62 µm) optional
Inboard leakage	2 x 10 <sup>-10</sup> sccs
Outboard leakage	2 x 10 <sup>-9</sup> sccs He
Leakage across seat	4 x 10 <sup>-8</sup> sccs He
Installation	surface or panel (optional)
Delivery pressure rise	3.5 psig per 100 psig source pressure drop
HF & FC	4.2 psig per 100 psig source pressure drop

### Materials

	Series AZ 1200 S	Series AZ 1200 SHP
Wetted Parts		
Body, nozzle	stainless steel 316L*	stainless steel 316L*
Poppet	stainless steel 316L	Hastelloy C-22
Diaphragm	Hastelloy® C-22®	Hastelloy C-22
Finish	electropolished and passivated	electropolished and passivated
Seat	PCTFE (Vespel® optional)	PCTFE

All specifications subject to change without notice.

\*Please refer to product note PN 414 regarding single melt 316L SS material.

Hastelloy® C-22® Haynes Corporation Vespel® DuPont

# SERVICE AND SUPPORT BEYOND COMPARE

## DIMENSIONAL INFORMATION

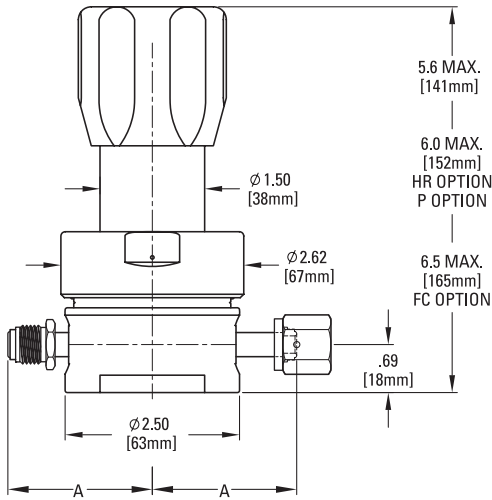

Face Seal	A	
	in	mm
1/4"	2.15 ±.01	55
3/8", 1/2"	2.61 ±.02	66

All dimensions in inches (mm).  
Metric dimensions are for reference only.

## PORTING CONFIGURATIONS

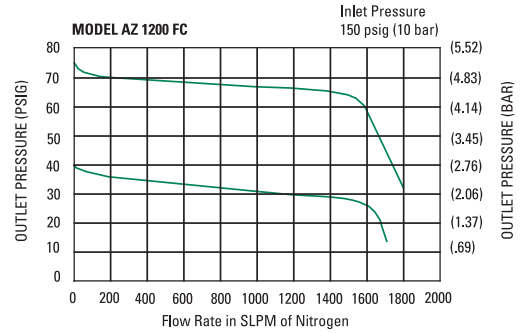
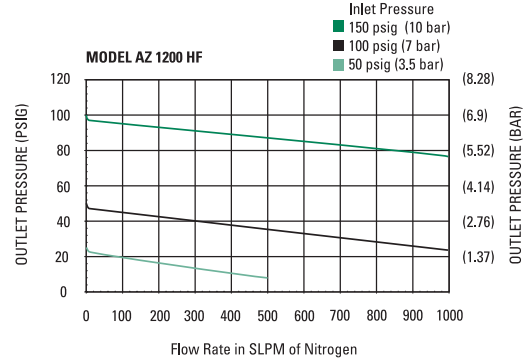
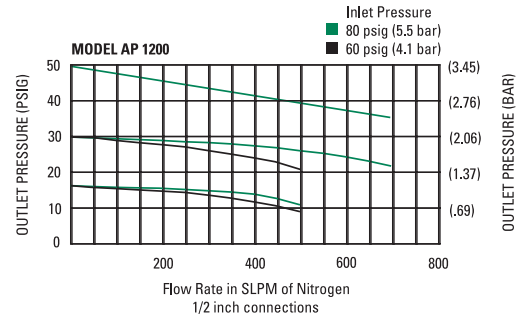
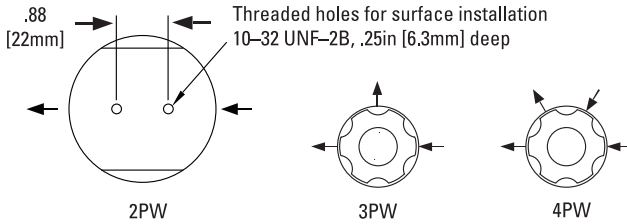

**CAUTION: Product selection is the sole responsibility of the user, regardless of any recommendations or suggestions made by the factory. The user shall make selections based upon their own analysis and testing with regard to function, material compatibility and product ratings. Proper installation, operation and maintenance are also required to assure safe, trouble free performance.**

## ORDERING INFORMATION

Sample Order Number	AZ 1210SQ 3PW FV8 FV8 V3 FC
<b>AZ 1210   Series</b>	AZ 1202 = 1-30 psig (.07 to 2 bar) AZ 1206 = 2-60 psig (.14 to 4 bar) AZ 1210 = 2-100 psig (.14 to 7 bar) AZ 1215 = 5-150 psig (.34 to 10 bar)
<b>S   Material</b>	S = Stainless steel (SS) SHP = SS/Hastelloy poppet and diaphragm
<b>Q   Surface Finish Option</b>	Q = 25 µin. Ra avg.
<b>3PW   Ports</b>	2PW = 2 ports butt weld 3PW = 3 ports butt weld 4PW = 4 ports butt weld

<b>FV8 FV8   Connections Inlet / Outlet</b>	FV4 = 1/4 inch face seal female MV4 = 1/4 inch face seal male FV6 = 3/8 inch face seal female MV6 = 3/8 inch face seal male FV8 = 1/2 inch face seal female MV8 = 1/2 inch face seal male  Tube weld stub available "FC" option only available with 1/2" connectors
<b>V3   Delivery Gauge*</b>	0 = No gauge V3 = 30-0-30 psig/bar L = 30-0-60 psig/bar 1 = 30-0-100 psig/bar H = 30-0-160 psig/bar  * Standard gauge port is 1/4 inch face seal male (1/4 inch female available).
<b>FC   Options</b>	HR = High Inlet Pressure*** HF = High Flow*** FC = Force Compensation*** P = Panel installation** VS = Vespel seat  ** Panel hole 1.56" diameter. ***HR, HF and FC options are only available separately. These options may not be combined.