



SERIES AZ 1400T

TIED DIAPHRAGM REGULATOR

Intermediate to high flow applications

- Single stage
- Stainless steel 316L
- Absolute sub-atmospheric option, flow rate to 6 slpm
- Cylinder or point of use specialty and bulk gases
- Flow rates to 600 slpm (21 scfm)
- Vacuum to 2,300 psig (159 bar) inlet
- Installation and operating instructions available at www.aptech-online.com in the Tech Briefs section

Operating Parameters

Source pressure	AZ 1400T	vacuum to 2,300 psig (159 bar)
	AZ 1400TA	vacuum to 300 psig (21 bar)
	AZ 1415T	vacuum to 1,000 psig (69 bar)
	AZ 1400T HR	vacuum to 3,000 psig (207 bar)
Delivery pressure	AZ 1402TA	100 mm Hg absolute to 30 psig (2 bar) (not available for HR)
	AZ 1402T	1 to 30 psig (0.07 to 2 bar) (not available for HR)
	AZ 1406T	1 to 60 psig (0.07 to 4 bar) (not available for HR)
	AZ 1410T	2 to 100 psig (0.14 to 7 bar)
	AZ 1415T	5 to 150 psig (0.34 to 10 bar)
Proof pressure		4,000 psig (276 bar); HR option 4,500 psig (310 bar)
Burst pressure		8,000 psig (552 bar); HR option 9,000 psig (620 bar)

Other Parameters

Inlet/outlet connectors	1/4, 3/8 or 1/2 inch face seal or tube weld
Flow coefficient (Cv)	0.45
Internal volume	1.06 in ³ (17.4 cm ³)
Operating temperature	-40° to +160°F (-40° to +71°C)
Surface finish	10 µin. (0.25 µm) Ra avg 25 µin. (0.62 µm) optional
Inboard leakage	2 x 10 ⁻¹⁰ sccs
Outboard leakage	2 x 10 ⁻⁹ sccs He
Leakage across seat	4 x 10 ⁻⁸ sccs He
Installation	surface or panel (optional)
Delivery pressure rise	1.6 psig per 100 psig source pressure drop

Materials

Series AZ 1400T S	
Wetted Parts	
Body, nozzle	stainless steel 316L*
Diaphragm, poppet	Hastelloy® C-22®
Finish	electropolished and passivated
Seat	PCTFE (Vespel® optional)

All specifications subject to change without notice.

Hastelloy® C-22® Haynes Corporation Vespel® DuPont

*Please refer to product note PN 414 regarding single melt 316L SS material.

ULTRACLEAN BY DESIGN

DIMENSIONAL INFORMATION

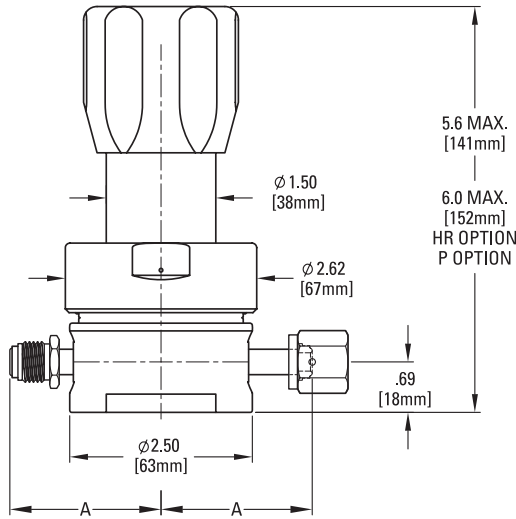

Face Seal	A	
	in	mm
1/4"	2.15 ±.01	55
3/8", 1/2"	2.61 ±.02	66

All dimensions in inches (mm).
Metric dimensions are for reference only.

PORTING CONFIGURATIONS

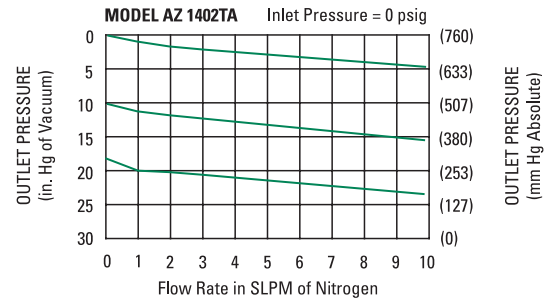
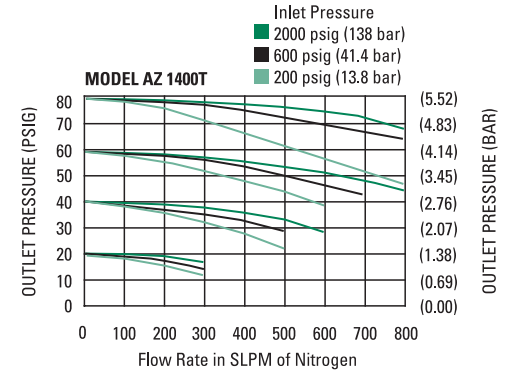
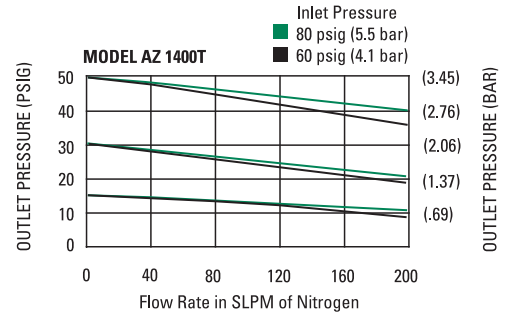
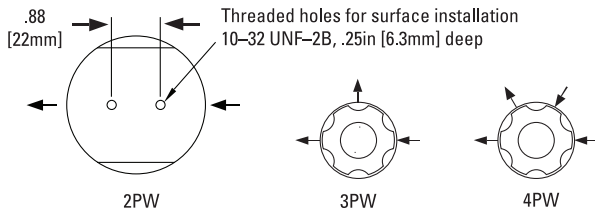

CAUTION: Product selection is the sole responsibility of the user, regardless of any recommendations or suggestions made by the factory. The user shall make selections based upon their own analysis and testing with regard to function, material compatibility and product ratings. Proper installation, operation and maintenance are also required to assure safe, trouble free performance.

ORDERING INFORMATION

Sample Order Number **AZ 1402TSQA 3PW FV4 FV4 V3**

AZ 1402T Series	AZ 1402T = 1-30 psig (.07 to 2 bar) AZ 1406T = 1-60 psig (.07 to 4 bar) AZ 1410T = 2-100 psig (.14 to 7 bar) AZ 1415T = 5-150 psig (.35 to 10 bar)
S Material	S = Stainless steel (SHP)*
Q Surface Finish Option	Q = 25 µin.
A Range Options	A = 100 mm Hg absolute to 30 psig (2 bar) (AP 1402T option only)
3PW Ports	2PW = 2 ports butt weld 3PW = 3 ports butt weld 4PW = 4 ports butt weld

FV4 FV4 | Connections Inlet / Outlet

- FV4 = 1/4 inch face seal female
- MV4 = 1/4 inch face seal male
- FV6 = 3/8 inch face seal female
- MV6 = 3/8 inch face seal male
- FV8 = 1/2 inch face seal female
- MV8 = 1/2 inch face seal male

Tube weld stub available

V3 | Gauges* Source / Delivery

- 0 = No gauge
- V3 = 30-0-30 psig/bar
- L = 30-0-60 psig/bar
- 1 = 30-0-100 psig/bar
- 2 = 0-200 psig/bar
- 4 = 0-400 psig/bar
- 10 = 0-1000 psig/bar
- 40 = 0-4000 psig/bar

* Standard gauge ports are 1/4 inch face seal male (1/4 inch face seal female are available).

| Options

- HR = High inlet pressure
- P = Panel installation**
- VS = Vespel seat

** Panel hole 1.56" diameter.

*S equivalent to SHP – stainless steel with Hastelloy poppet and diaphragm