

Series AK M80
Crossover Manifold

INSTALLATION AND OPERATION
MANUAL

Part Number 00-15000010

Revision 1

Copyright © July 2006

Advanced Pressure Technology (“AP Tech”)

687 Technology Way

Napa, CA 94558

Phone: (707) 259-0102

FAX: (707) 259-0117

TABLE OF CONTENTS

1.DESCRPTION.....	3
2.SAFETY.....	4
2.1.General Safety Information.....	4
2.2.AK M80 Crossover Manifold Specific Safety Information.....	4
3.TECHNICAL SPECIFICATIONS.....	5
3.1.AK M80 Specifications.....	5
3.2.AK M80 Facility Requirements.....	5
4.INSTALLATION.....	6
4.1.General.....	6
4.2.AK M80 Installation.....	6
4.3.Connect Gas Lines to M80.....	7
4.4.Relief Valve Installation.....	8
4.5.Purge and Vent Equipment.....	8
4.6.Initial Leak Test.....	9
5.OPERATION.....	10
5.1.AK M80 Operation.....	10
6.TROUBLESHOOTING.....	13
6.1.External leak.....	13
6.2.Relief valve is opening and venting gas.....	13
6.3.High delivery line pressure.....	13
6.4.Low delivery line outlet pressure.....	14
6.5.Both cylinders empty simultaneously.....	14

1. DESCRIPTION

This installation and operation manual covers the series AK M80 crossover manifold. The AK M80 crossover manifold is used to maintain a continuous supply of source gas when the “in use” gas cylinder is depleted by automatically drawing gas from a standby cylinder. The AK M80 consists of a *crossover regulator* and a *line regulator* mounted to a common panel. The crossover regulator consists of two regulators with separate inlets and a common outlet, machined into a single body. Two pressure gauges are installed in the crossover regulator to indicate the inlet pressure from the *A Side* and *B Side* gas cylinders. The crossover regulator supplies the line regulator. The crossover regulator has a plugged outlet port at the 6:00 o’clock position for installation of a relief valve. A relief valve is recommended to protect the low pressure side of the crossover regulator from full cylinder pressure in the event of a seat failure. The line regulator has one primary outlet port, a secondary plugged outlet port, and a pressure gauge that indicates outlet pressure. Custom configurations may vary slightly from this standard design. Figure 1 shows the basic design.

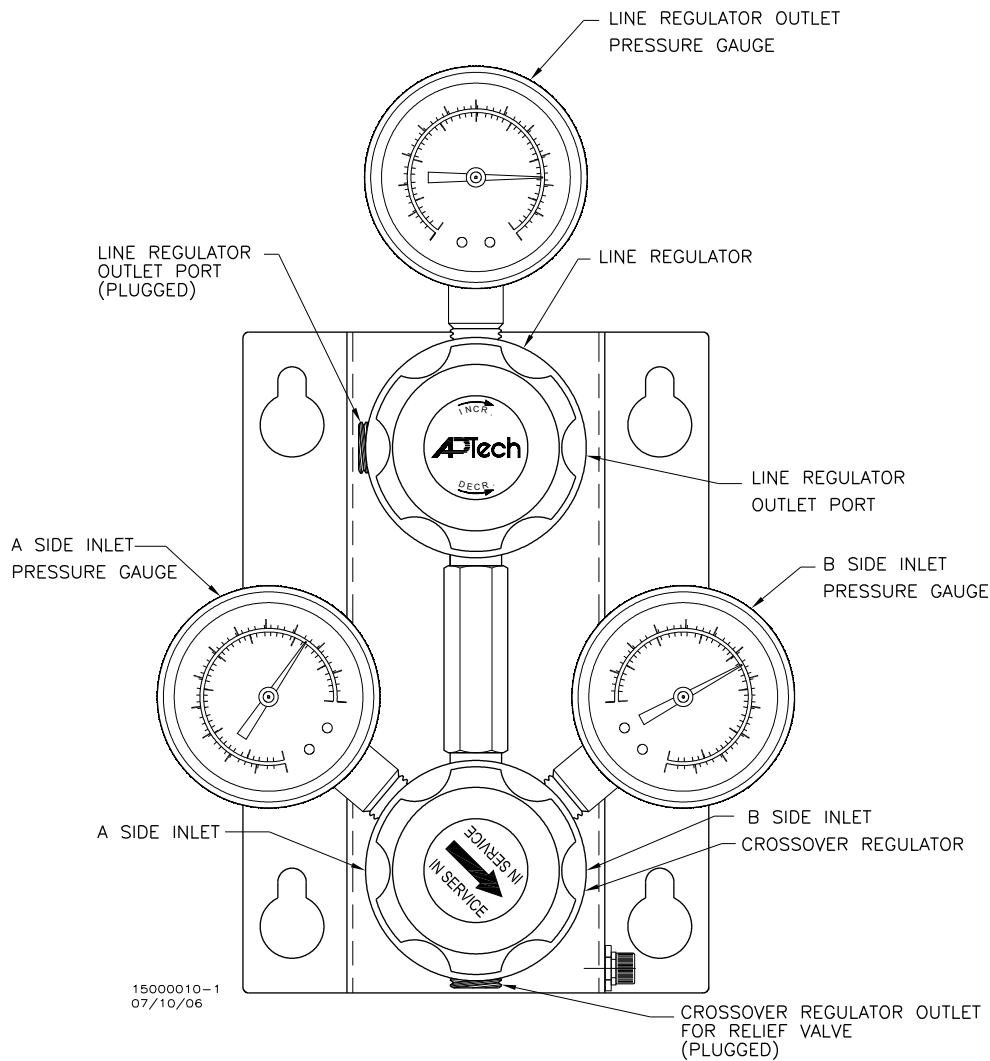

Figure 1. AK M80 Crossover Manifold Front View

2. SAFETY

The user is strongly recommended to carefully read this section covering general safety information and to adhere to specific safety information located throughout this manual.

2.1. General Safety Information

All technicians that install, operate, or maintain this equipment should be trained in the use and hazards of compressed gases. Technicians should also be familiar with the hazards associated with the particular gas being delivered. These hazards can include high pressure, asphyxiation, toxicity, flammability, corrosivity, etc. Material safety data sheets are available from gas suppliers that provide detailed information on the hazards associated with a particular gas.

Appropriate personnel protective equipment should be worn at all times as recommended by the material safety data sheet for the particular gas and as required by safety practices at the installation site. This equipment may include safety glasses, safety shield, rubber gloves, aprons, etc.

Never exceed the maximum working pressure of the equipment.

Equipment shall be installed in a manner that meets local, state, and federal regulations and safety guidelines. General guidelines for compressed gases can be obtained from the Compressed Gas Association (<http://www.cganet.com/>) and the European Industrial Gases Association (www.eiga.org).

Prior to disassembling manifold lines, the system may need to be purged using nitrogen or another gas to remove any hazardous gases. The AK M80 system does not have built-in purging capability, which is the responsibility of the user.

2.2. AK M80 Crossover Manifold Specific Safety Information

An overpressure relief device should be installed in the plugged low-pressure (6:00 o'clock) port of the crossover regulator. The outlet of the relief device should be connected to a scrubber system or directed away from personnel as appropriate.

The AK M80 manifold should be checked for leaks upon installation and inspected periodically during use.

A shut off valve and check valve should be installed between the both supply cylinders and the AK M80 manifold inlet connections to prevent gas from the cylinder in use from escaping when a cylinder is being replaced.

Installation of purge and vent valves are recommended when used with hazardous gases and exposure to the gas can result in a safety hazard to personnel. Purge equipment is the responsibility of the user.

3. TECHNICAL SPECIFICATIONS

3.1. AK M80 Specifications

3.1.1. Physical

- Dimensions are approximately 6 inch wide by 10 inch high by 8-1/2 inch deep
- Weight is approximately 9 lbs.
- Mounting is by 4 each 1/4 inch diameter screws

3.1.2. Pressure and Flow

- 3500 psig maximum inlet pressure
- 250, 150, 100, or 60 psig maximum outlet pressure options (specified when ordered)
- 75 slm nitrogen maximum flow at 200 psig minimum inlet pressure (depending on line regulator outlet pressure setting)

3.2. AK M80 Facility Requirements

The following is needed to install the AK M80 manifold at the users facility.

- Horizontal strut channel or wall with anchor bolts
- 1/4 inch diameter, hex head type screws (1/4-20 or 1/4-28 thread acceptable)

The following is required for proper operation of the equipment:

- Check valve for installation between cylinder and regulator inlet port
- Manual valve for installation between cylinder and check valve
- Appropriate purge and vent system for hazardous gases
- Relief valve for installation on crossover regulator low pressure port
- Relief valve for installation on line regulator low pressure port

4. INSTALLATION

This section describes how to install the equipment at a user facility.

4.1. General

Use Teflon® pipe thread tape on NPT connections. When mating a 316 stainless steel pipe fitting to a 316 stainless steel AK M80 body, it is recommended that Teflon tape be applied to the first NPT thread to prevent galling upon assembly. For brass fittings, do not apply thread tape to the first NPT thread to reduce the chance of introducing pieces of thread tape into the system. Use care not to apply Teflon tape such that loose tape will come free and enter the flow path.

Do not drop or jar the switchover manifold because damage to internal parts and pressure gauges may result.

Inspect the manifold after unpacking and before installation. If any damage is observed, contact factory for repair.

4.2. AK M80 Installation

Select a location for the manifold that is sheltered from the environment and away from sources of heat or sparks. The area should be protected from vehicles and moving mechanical equipment. The area must be accessible for ease of cylinder replacement.

It is recommended that the screw head maximum size be 5/8 inch diameter so that the mounting panel large holes can easily slip over the screw head. Two possible methods to mount the manifold are given below.

- Install two metal framing channels (i.e. Unistrut® type or equivalent) horizontally on the wall and parallel to each other. Space the channels 5-1/4 inches apart on center. Secure the AK M80 manifold to the channel using 1/4 inch screws.
- Install anchors in the wall using the pattern shown on Figure 2 or hold the AK M80 manifold against a wall and mark the location of the mounting holes. Mount the AK M80 manifold directly to the wall and secure with 1/4 inch diameter screws.

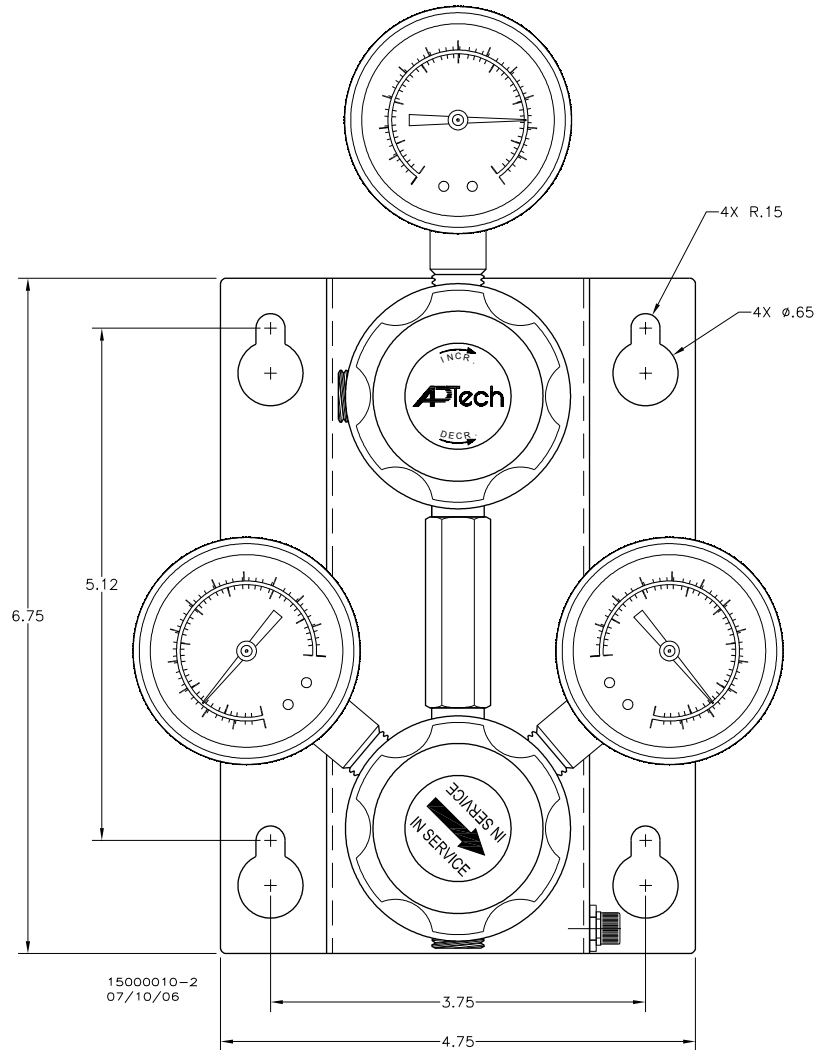

Figure 2. AK M80 Crossover Manifold Mounting Hole Pattern

4.3. Connect Gas Lines to M80

Position a gas cylinder on each side of the AK M80 panel. Secure cylinders in place using an appropriate restraint system.

Equipment can be supplied with various types of fittings and connections. The standard connections are 1/4 inch female NPT. Inspect the system to determine if the connection is NPT, tube compression, or other.

Install a check valve into port labeled “HP-A” on AK M80 manifold. Flow arrow on check valve should be pointing into the AK M80 manifold inlet port. Install manual shut off valve onto check valve.

Install a check valve into port labeled “HP-B” on AK M80 manifold. Flow arrow on check valve should be pointing into the AK M80 manifold inlet port. Install manual shut off valve onto check valve.

Connect a “pigtail” (bent piece of tubing with loops for flexibility and to reduce stress on connections) or flexible braided hose from the outlet of the left cylinder valve to the manual valve on the AK M80 manifold regulator inlet port labeled “HP-A”.

Connect a “pigtail” (bent piece of tubing with loops for flexibility and to reduce stress on connections) or flexible braided hose from the outlet of the left cylinder valve to the manual valve on the AK M80 manifold regulator inlet port labeled “HP-B”.

Install appropriate fitting into line regulator 1/4 NPT female outlet port. Install delivery line to point of use using tubing or piping.

4.4. Relief Valve Installation

Remove 1/4 NPT plug from port on AK M80 crossover regulator. Clean Teflon thread tape from port. Install a relief valve that is set above the AK M80 crossover regulator pressure settings. See Table 1 for recommended nominal relief valve set pressures. If necessary due to gas properties, route the relief valve outlet line to an appropriate scrubber or exhaust system. Otherwise, direct the relief valve outlet away from personnel.

AK M80 Model	Nominal Crossover Regulator Outlet Range	Relief Valve Set Pressure
AK M8002	85-115 psig	150 psig
AK M8010	135-165 psig	200 psig
AK M8015	225-275 psig	325 psig
AK M8025	435-515 psig	600 psig

Table 1. Crossover Relief Valve Nominal Set Pressures

It is also suggested that a relief valve be installed in the plugged outlet port of the AK M80 line regulator. Remove 1/4 NPT plug from outlet port on AK M80 line regulator. Clean Teflon thread tape from port. Install a relief valve that is set above the AK M80 line regulator maximum outlet pressure. See Table 2 for recommended nominal relief valve set pressures. If necessary due to gas properties, route the relief valve outlet line to an appropriate scrubber or exhaust system. Otherwise, direct the relief valve outlet away from personnel.

AK M80 Model	Line Regulator Maximum Outlet	Relief Valve Set Pressure
AK M8002	30 psig	50 psig
AK M8010	100 psig	150 psig
AK M8015	150 psig	200 psig
AK M8025	250 psig	300 psig

Table 2. Line Regulator Relief Valve Nominal Set Pressures

4.5. Purge and Vent Equipment

If required due to gas properties (such as for hazardous gases), install purge and vent valves to enable the operator to remove hazardous gases from the lines using an inert purge gas before connecting and disconnecting gas cylinders.

4.6. Initial Leak Test

Connect a nitrogen (or other appropriate gas) cylinder with a pressure regulator to both inlets on the AK M80 manifold. Regulate the pressure to less than the manifold maximum inlet pressure and no more than 90% of the inlet gauge maximum range.

Pressurize the manifold with nitrogen. Increase the line regulator to the maximum outlet.

Check all lines for leaks by listening for audible leakage and applying soap solution to NPT connections. Disassemble, repair, and retest all leaks.

Disconnect the nitrogen cylinder.

Fully close (turn knob counterclockwise) the AK M80 line regulator.

5. OPERATION

This section describes operation of the AK M80 crossover manifold.

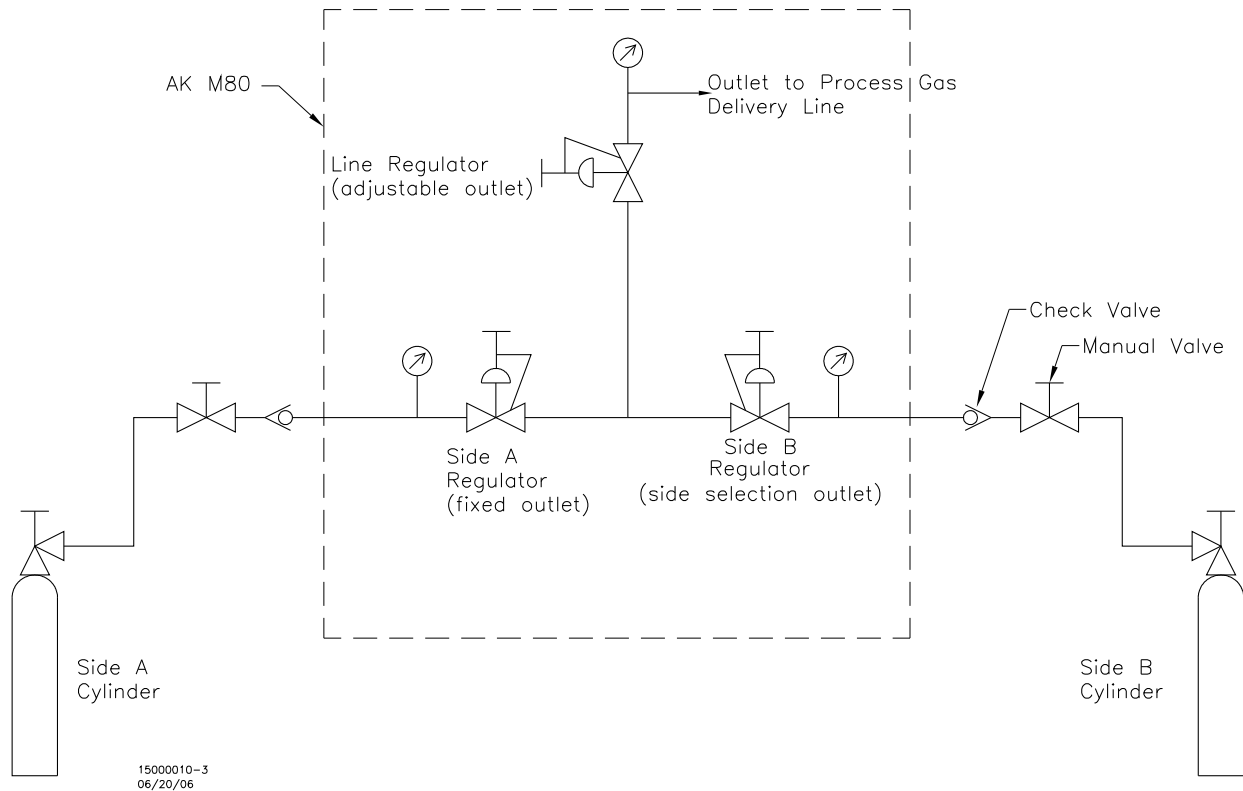

Figure 3. AK M80 Installation Schematic

5.1. AK M80 Operation

5.1.1. General Principle of Operation

The knob for the crossover regulator has an “IN SERVICE” label with an arrow. When the knob is turned so that the arrow points toward the *B Side* (right) cylinder (approximately the 4:30 o’clock position with the line regulator at 12:00 o’clock position), then the *B Side* (right) cylinder is the primary gas supply and the *A Side* (left) cylinder is the standby gas supply. When the knob is turned so that the arrow points toward the *A Side* (left) cylinder (approximately the 7:30 o’clock position), then the *A Side* (left) cylinder is the primary gas supply and the *B Side* (right) cylinder is the standby gas supply.

The crossover regulator is comprised of a fixed outlet pressure regulator and an adjustable (limited range) outlet pressure regulator. The *A Side* (left) cylinder supplies the fixed outlet pressure regulator. The *B Side* (right) cylinder supplies the adjustable outlet pressure regulator. The adjustable outlet pressure regulator has the “side selection outlet” knob with the “IN SERVICE” label and arrow. This regulator can be rotated only 270 degrees to adjust the *B Side* outlet pressure slightly above or slightly below the *A Side* fixed outlet pressure. It is this slight change in *B Side* outlet pressure that *selects* which cylinder is supplying gas and which cylinder is on standby. When the cylinder supplying gas is empty, then it is time to replace that cylinder using the protocol in Section 5.1.3 or 5.1.4 as appropriate.

The line regulator is used to maintain a constant delivery pressure since the outlet pressure from the upstream crossover regulator fluctuates as *A Side* and *B Side* cylinders empty and are replaced. The line regulator is fully adjustable to the maximum outlet pressure. Rotating the knob clockwise increases the line regulator outlet pressure.

5.1.2. Initial Pressurization

Confirm that an initial leak test has been performed and all leaks repaired.

Close all system valves.

Close line regulator by turning knob counterclockwise.

Turn side selection knob on AK M80 crossover regulator clockwise until internal stop is contacted. The “IN SERVICE” label arrow on the knob should be pointing toward the *B Side* (right) cylinder (approximately the 4:30 o’clock position).

Open *B Side* cylinder valve and manual valve between *B Side* (right) cylinder and AK M80 crossover manifold. Pressure on *B Side* (right) gauge should indicate the cylinder pressure.

Open *A Side* cylinder valve and manual valve between *A Side* (left) cylinder and AK M80 crossover manifold. Pressure on *A Side* (left) gauge should indicate the cylinder pressure.

Adjust line regulator (clockwise) to desired delivery pressure setting as indicated on pressure gauge.

Check all system connections for leaks. This can be done with soap solution on each connection, by listening for an audible hissing sound, or by using an appropriate gas detector.

5.1.3.B Side (right) Cylinder Depleted

Confirm that *B Side* (right) side cylinder is depleted by reading the pressure gauge. The exact pressure will depend on the specific AK M80 model. The approximate pressure when the *B Side* cylinder is depleted is given in Table 3.

Rotate AK M80 crossover manifold “selection” knob counterclockwise until internal stop is contacted. The knob will rotate approximately 270 degrees. The “IN SERVICE” label arrow on the knob should be pointing toward the *A Side* (left) cylinder (approximately the 7:30 o’clock position).

Close *B Side* (right) cylinder valve and manual valve between *B Side* (right) cylinder and AK M80 crossover manifold. If required, operate equipment to purge line from cylinder to manifold.

Disconnect depleted *B Side* cylinder and connect full cylinder.

Open *B Side* (right) cylinder valve and manual valve between *B Side* (right) cylinder and AK M80 crossover manifold. Pressure on *B Side* (right) gauge should indicate the cylinder pressure.

AK M80 Model	<i>B Side</i> Depletion Pressure, psig
AK M8002	100
AK M8010	150
AK M8015	250
AK M8025	475

Table 3. Approximate *B Side* Cylinder Depletion Pressure

5.1.4. Cylinder “A” Depleted

Confirm that *A Side* (left) side cylinder is depleted by reading the pressure gauge. The exact pressure will depend on the specific AK M80 model. The approximate pressure when the *A Side* cylinder is depleted is given in Table 4.

Rotate AK M80 crossover manifold “selection” knob clockwise until internal stop is contacted. The knob will rotate approximately 270 degrees. The “IN SERVICE” label arrow on the knob should be pointing at approximately 4:30 o’clock position toward the *B Side* (right) cylinder.

Close *A Side* (left) cylinder valve and manual valve between *A Side* (left) cylinder and AK M80 crossover manifold. If required, operate equipment to purge line from cylinder to manifold.

Disconnect depleted *A Side* cylinder and connect full cylinder.

Open *A Side* (left) cylinder valve and manual valve between *A Side* (left) cylinder and AK M80 crossover manifold. Pressure on *A Side* (left) gauge should indicate the cylinder pressure.

AK M80 Model	<i>A Side</i> Depletion Pressure, psig
AK M8002	85
AK M8010	135
AK M8015	225
AK M8025	435

Table 4. Approximate *A Side* Cylinder Depletion Pressure

6. TROUBLESHOOTING

The most common problem conditions and possible causes/corrections are described below. Please contact the factory for assistance with other problem conditions or to discuss a specific problem in more detail.

6.1. External leak

Possible causes:

Connection not assembled properly with Teflon tape.

Connection not tightened properly.

Correction:

Inspect equipment to determine source of the leak. Repair leak by disassembling the connection, inspecting parts, and reassembling using good shop practice.

If the leak is from the bonnet of the regulator, then AP Tech recommends that the AK M80 manifold be sent back to the factory for repair (however, a field repair kit is available).

6.2. Relief valve is opening and venting gas

Possible causes:

Relief valve opens below set pressure.

Seat leak on AK M80 crossover regulator causing an overpressure condition.

Correction:

Remove and bench test relief valve. Replace relief valve if defective.

If relief valve operates correctly, then temporarily install a pressure gauge in relief valve port of AK M80 manifold and monitor pressure. A continuous pressure rise after initial pressurization indicates a seat leak on the AK M80 crossover regulator. If the problem is a seat leak, then AP Tech recommends that the AK M80 manifold be sent back to the factory for repair (however, a field repair kit is available).

6.3. High delivery line pressure

Possible causes:

Other gas source from point of use is pressurizing delivery line.

Seat leak or high creep on line regulator.

Regulator knob adjusted incorrectly.

Correction:

Check to see if a different gas source can be pressurizing the line.

If another gas source is not the cause of the high delivery line pressure, then shut off the supply to the point of use, close the line regulator, vent the delivery line, and readjust to desired outlet pressure. If the line outlet pressure continues to rise above the set pressure, then it is likely the line regulator has a seat leak and AP Tech recommends that the AK M80 manifold be sent back to the factory for repair (however, a field repair kit is available). If the outlet pressure does not change significantly, then it is likely the regulator was adjusted incorrectly.

6.4. Low delivery line outlet pressure

Possible causes:

Flow restriction.

High flow at point of use

Regulator knob adjusted incorrectly.

Correction:

Shut off the supply to the point of use and see if the line outlet pressure returns to normal setting. If outlet pressure returns to normal, then high flow or a flow restriction is the likely cause. Check the flow requirement at the point of use.

If line outlet pressure is still low, readjust the line regulator knob to desired pressure. If line outlet pressure returns to normal, then it is likely that the regulator was adjusted incorrectly.

6.5. Both cylinders empty simultaneously

Possible causes:

External leak on high pressure connection from standby cylinder to AK M80 crossover manifold.

Vent valve leaking past seat (if installed).

High flow at point of use.

Seat leak on crossover regulator supplied by standby gas cylinder.

Correction:

Check for external leaks especially on the high pressure line from the standby cylinder to the AK M80 crossover manifold.

If there is a vent valve on the line from the gas cylinder to the AK M80 crossover manifold, check to see if the vent valve is leaking across the seat.

Verify the flow demand is below the manifold rating. In general, high flow will empty the "IN SERVICE" cylinder faster than the standby gas cylinder.

Momentarily shut off the cylinder valve on the standby gas cylinder. If the pressure on the standby gas cylinder pressure gauge drops, then high flow demand or a seat leak on the regulator supplied by the standby gas cylinder is the probably cause.