

Operation Manual

Piston Sensed Gas Pressure Regulators

(Models KT10, KT10—Welded, KT12)

A. General information

AP Tech pressure regulators are used in gas delivery systems to reduce the source pressure to a lower delivery pressure. This operation manual is applicable to gas pressure regulators that use a piston to sense the outlet pressure.

Refer to the appropriate catalog data sheet for specific product information. For special options that are not shown in the data sheet, contact the factory or your local representative for questions on proper operation.

B. System Design/Product Selection

1. AP Tech piston sensed gas pressure regulators are **not** safety accessories per EU Pressure Equipment Directive 97/23/EC or safety related devices per EU ATEX Directive 94/9/EC. The EU Pressure Equipment Directive requires the system designer to install a safety accessory (for example, safety relief valve or burst disc) where the design pressure of the downstream system is lower than the upstream pressure.
2. When selecting the pressure regulator model and configuration, verify the following information.
 - a. Verify the materials of construction are compatible with the intended process gas.
 - b. Verify the pressure and temperature ratings are acceptable for the intended application.
 - c. If the regulator is to be equipped with either a supply or delivery pressure gauge, verify that the pressure gauge range is suitable for the application.
 - d. Verify that the flow capability of the regulator is appropriate for the application.
3. Pressure regulators can be used under a large variety of operation conditions. The system designers shall decide product selection based upon their own analysis and testing to verify acceptable operation with specific equipment.

C. Installation

1. Verify the pressure rating is acceptable for the intended application.
2. If the regulator is equipped with either a supply or delivery pressure gauge, verify that the pressure gauge range is suitable for the application.
3. Inspect the regulator to determine the flow path through the regulator and how the regulator will need to be installed in the system.
 - a. The high pressure (inlet) port(s) is labeled with an “HP” marked on the body near the port. Arrows are sometimes used next to the HP characters to point toward a high pressure port.

- b. The low pressure (outlet) port(s) is labeled with an “LP” marked on the body near the port. Arrows are sometimes used next to the LP characters to point toward a low pressure port.
- c. Always connect the gas source to the high pressure port. Never connect the gas source to the low pressure port as the regulator can be damaged and leakage can result.

Caution: If a regulator was installed incorrectly and a low pressure port was pressurized above the rated outlet pressure, then the regulator must be returned to the factory for repair prior to use.

4. Install the regulator using the appropriate method described below. For assembly of other type connections, consult connector manufacturer or contact the factory.
 - a. For NPT connections, apply PTFE (e.g. Teflon) tape to connector threads and install connector in regulator body wrench tight.
 - b. For straight thread o-ring connections (such as MS33649 porting), verify the proper mating fittings and o-rings are being used and install the fittings in the regulator. Tighten according to fitting manufacturer specification.
 - c. For metal face seal connectors (KT10—Welded), assemble connections per standard practice described by fitting supplier (typically 1/8 turn past fingertight).
5. If appropriate for the application, secure the regulator body using one of the below methods.
 - a. For KT10 and KT12 regulators with NPT or straight thread connections, use the panel mount clamp option to secure the regulator. It may be necessary to remove the regulator wheel to install the regulator through the panel. Refer to Figure 1 to remove closure, retaining ring, wheel, and thrust washer. Refer to Figure 2 for panel mount clamp installation. Loosen the 10-32 screws on the clamp using a 5/32 inch hex wrench. Position the clamp on the regulator body so the 1/4-20 UNC threaded holes line up with the panel cutout, then retighten the 10-32 screws leaving the same gap between each half of the panel mount clamp. Install and tighten 1/4-20 UNC screws (customer supplied) to secure regulator to panel. Reinstall the thrust washer, wheel, retaining ring, and closure.
 - b. For KT10—Welded regulators with metal face seal connections, use the mounting holes in the bottom of the body to secure the regulator with 10-32 UNF screws.
6. After installation, perform a leak test. A pressure decay leak test is recommended to check for leak integrity of the regulator internal parts and external fitting connections. A bubble leak test may be performed to check for leaks at external fitting connections. A helium leak test is recommended for KT10—Welded regulators with face seal connections per standard industry practice (reference SEMI standard F1).

D. Adjustable, Non-relieving (non-venting) Regulator Operation

Note: A pressure regulator should not be used as a positive shut-off device.

Caution: Do not pressurize the regulator outlet, except by rotating the adjustment wheel clockwise (increasing the set point), as damage to the regulator internal parts or leakage may result.

1. Perform the following to increase the regulator set point.
 - a. Before opening the source valve, verify that the regulator adjustment wheel is turned fully counterclockwise (fully decreased position).
 - b. Slowly open the source valve to pressurize the regulator high pressure port.

- c. Rotate the regulator wheel clockwise to increase the delivery pressure to the desired set point.
 - d. In order to obtain a precise set point under flowing conditions, the regulator wheel should be adjusted at the desired flow condition.
2. Perform the following to decrease the regulator set point for non-relieving (non-venting) regulators.
 - a. Open a downstream valve to initiate a flowing condition.
 - b. Rotate the regulator wheel counterclockwise to reduce the delivery pressure below the desired set point.
 - c. Close the downstream valve to stop flow.
 - d. Rotate the regulator wheel clockwise to increase the delivery pressure to the desired set point.
 - e. In order to obtain a precise set point under flowing conditions, the regulator wheel should be adjusted at the desired flow condition.
3. Perform the following to fully decrease the regulator.
 - a. Close the source valve.
 - b. Vent to atmospheric pressure on both sides of the pressure regulator.
 - c. Rotate the regulator wheel fully counterclockwise.

E. Adjustable, Self-relieving (self-venting) Regulator Operation

Note: A pressure regulator should not be used as a positive shut-off device.

Caution: Do not pressurize the regulator outlet, except by rotating the adjustment wheel clockwise (increasing the set point), as damage to the regulator internal parts or leakage may result.

Many piston sensed pressure regulators have an internal vent mechanism that allows the outlet pressure to be reduced during the counterclockwise rotation of the adjustment wheel. A self-relieving regulator should only be used with gases that can be safely released in the area where the regulator is being used. The self-relieving mechanism incorporated into AP Tech piston sensed regulators will come from the factory preset and should not need adjustment. If any of the below conditions occur, then adjust the vent valve setting per section E.4.

- The regulator does not relieve its outlet pressure after several counterclockwise rotations of the adjustment wheel.
 - Audible venting is detected inside the regulator bonnet with a stable outlet pressure set point, and the adjustment wheel has not been rotated.
 - Audible venting is detected inside the regulator bonnet while increasing the outlet pressure of the regulator by rotating the adjustment wheel clockwise.
1. Perform the following to increase the regulator set point.
 - a. Before opening the source valve, verify that the regulator adjustment wheel is turned fully counterclockwise (fully decreased position).
 - b. Slowly open the source valve to pressurize the regulator high pressure port.
 - c. Rotate the regulator wheel clockwise to increase the delivery pressure to the desired set point.

- d. In order to obtain a precise set point under flowing conditions, the regulator wheel should be adjusted at the desired flow condition.
2. Perform the following to decrease the regulator set point for self-relieving (self-venting) regulators.
 - a. Slowly rotate the regulator wheel counterclockwise to reduce the delivery pressure below the desired set point. The self-relieving feature will vent the downstream pressure through the regulator bonnet to atmosphere.
 - b. Rotate the regulator wheel clockwise to increase the delivery pressure to the desired set point.
 - c. In order to obtain a precise set point under flowing conditions, the regulator wheel should be adjusted at the desired flow condition.
3. Perform the following to fully decrease the regulator.
 - a. Close the source valve.
 - b. Vent to atmospheric pressure on both sides of the pressure regulator.
 - c. Rotate the regulator wheel fully counterclockwise.
4. Perform the following to adjust the vent valve (refer to Figure 1).
 - a. Remove the closure (6) on the top of the regulator adjustment wheel (4).
 - b. Rotate the adjustment wheel clockwise to set the outlet pressure to approximately 10% of regulator's rated outlet pressure or 200 psig whichever is greater, with all valves downstream of the regulator closed.
 - c. Use a flat tip screwdriver to turn the vent screw (9) clockwise until gas can be heard venting through the bonnet of the regulator.
 - d. Once venting is heard, turn the vent screw counterclockwise until audible gas flow stops plus one half additional turn.
 - e. Replace the closure on the top of the adjustment wheel.

F. Preset Regulator Operation

Note: Preset regulators are adjusted at the factory to customer specified conditions. Generally, no adjustment will be required.

1. Perform the following to readjust the regulator set point. Refer to Figure 1.
 - a. Close the source valve.
 - b. Vent to atmospheric pressure on both sides of the pressure regulator.
 - c. Remove acorn nut (8) from top of stem (2).
 - d. Loosen jam nut (7).
 - e. Place a 3/8 inch open end wrench on stem flats and rotate stem fully counterclockwise (fully decreased position).
 - f. Slowly open the source valve to pressurize the regulator high pressure port to the desired inlet pressure.
 - g. Using 3/8 inch wrench on stem flats, turn stem clockwise to increase the delivery pressure to the desired set point.
 - h. In order to obtain a precise set point under flowing conditions, the regulator wheel should be adjusted at the desired flow condition.

- i. Reinstall jam nut and tighten to 100 in-lb against regulator bonnet.
- j. Reinstall acorn nut and tighten to 40 in-lb against jam nut.

Please contact the factory or your local representative to answer questions or for further information.

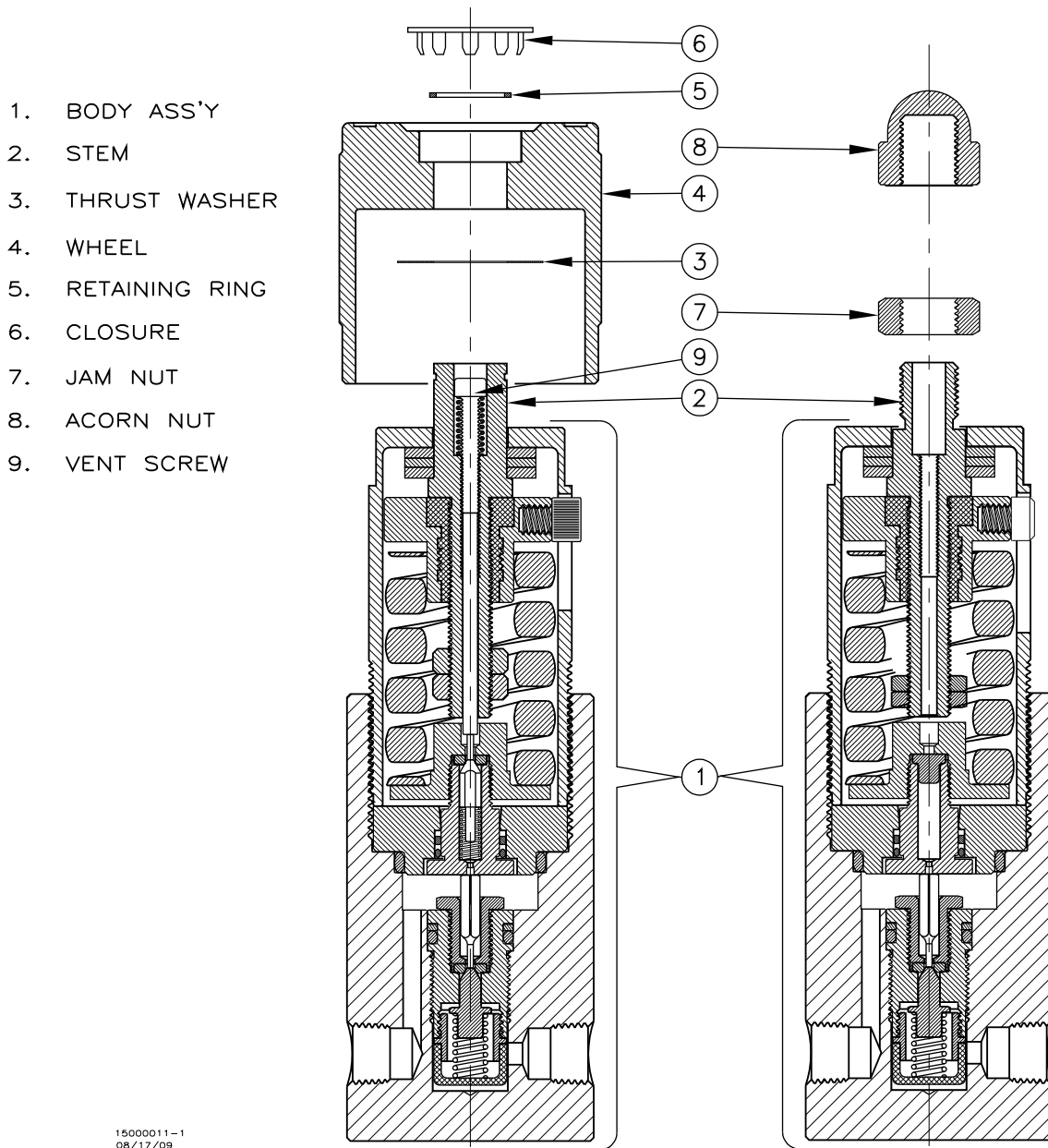

15000011-1
08/17/09

Figure 1. KT Adjustable and Preset Regulator

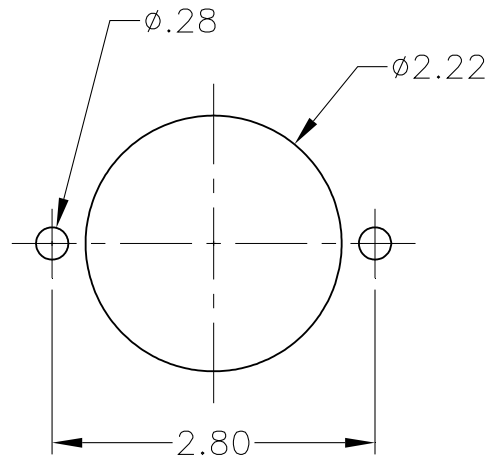
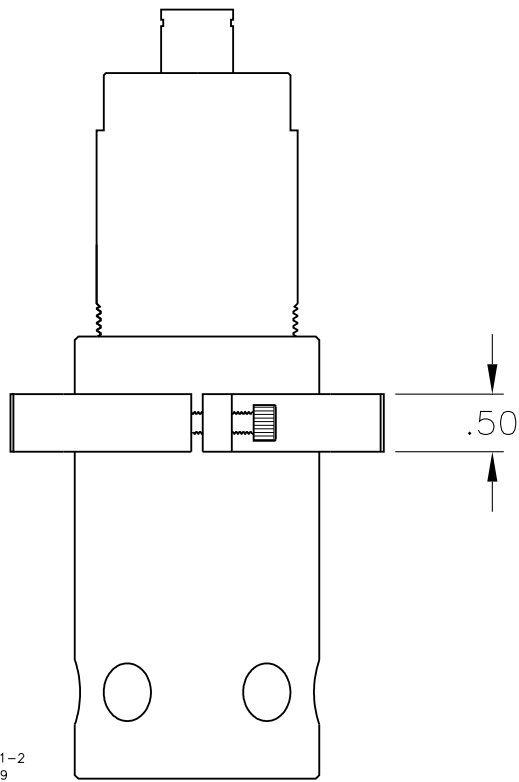
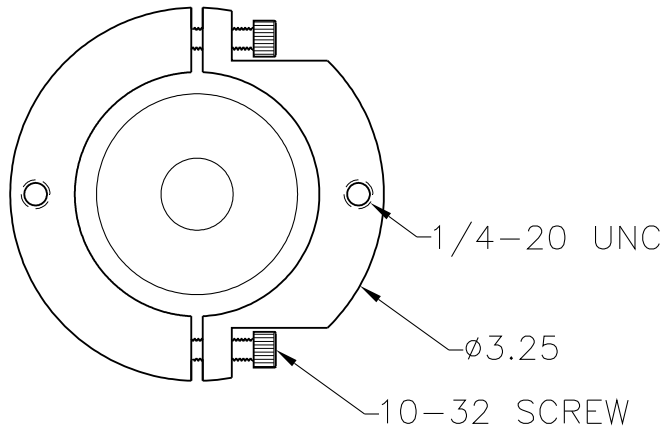

KT REGULATOR WITH PANEL MOUNT CLAMP (WHEEL REMOVED)

PANEL CUTOUT

Figure 2. KT Panel Mount Clamp Detail