

DUAL 'V' VALVE MONOBLOCK SERIES DV

TECHNICAL BULLETIN 205A

TABLE 1. MONOBLOCK CONFIGURATION

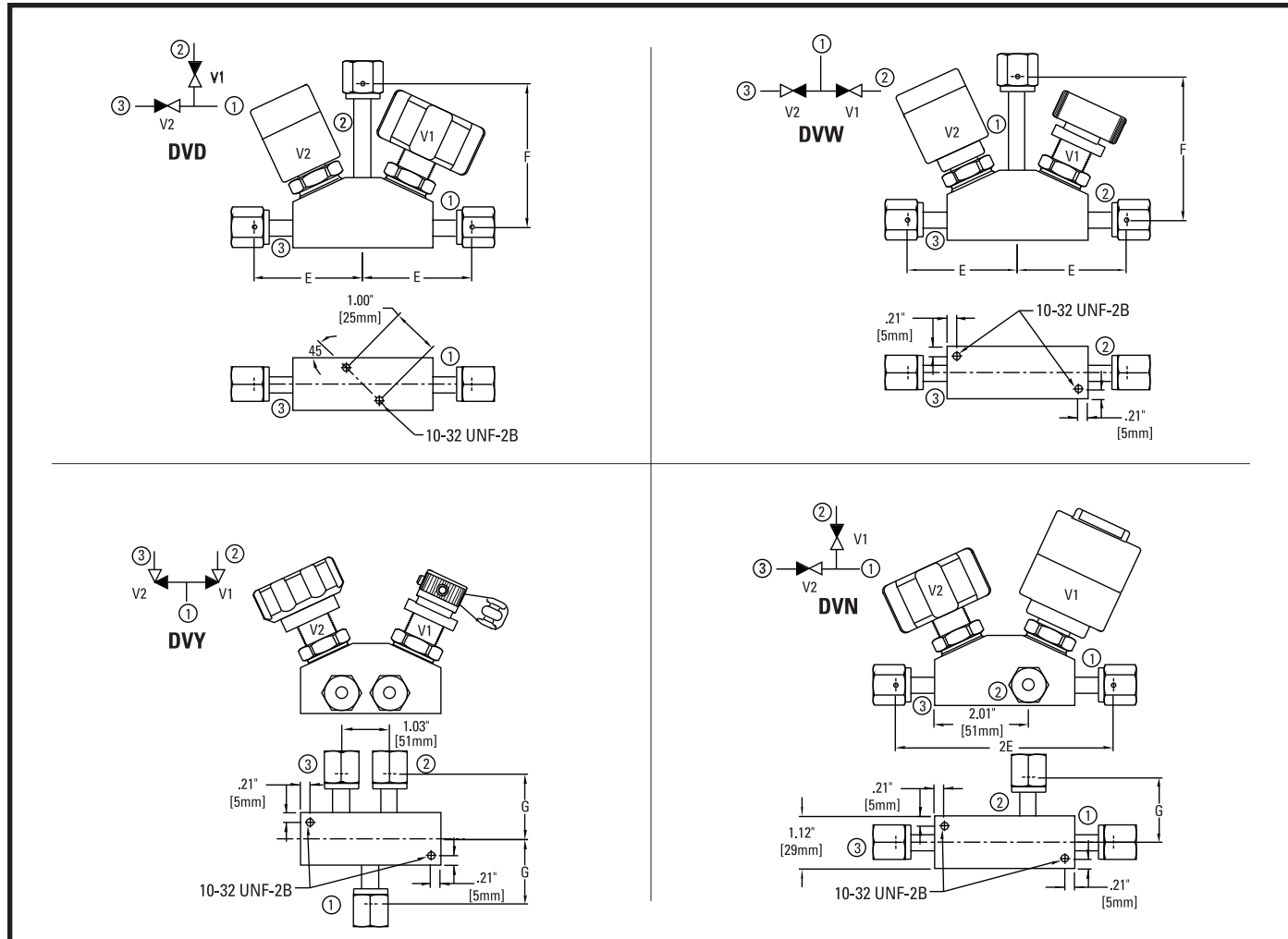

- Valve specifications and available options determined by actuator selection. Please refer to individual data sheet for the selected series actuator to review the specifications for V1 and V2.
- Monoblocks are available with any combination of actuators. Refer to Table 2 for selection.
- Port connection type designated in model number in numerical order; ① ② ③
- Mounting hole location varies per configuration type.
- Configuration and dimension drawing available upon request.

DUAL 'V' MONOBLOCK

TABLE 2. ACTUATOR CONFIGURATION

ACTUATOR	A	B	C	Pressure Rating	Cv
AP3000	~4.21" [107mm]	~2.91" [74mm]	Ø1.98" [50mm]	3,000psi (207 bar)	0.23
AP3540	~3.68" [93mm]	~2.59" [66mm]	Ø1.46" [37mm]	125psi (9 bar)	0.29
AP3550	~3.48" [88mm]	~2.41" [61mm]	Ø1.37" [35mm]	250psi (17 bar)	0.29
AP3580	~3.38" [86mm]	~2.44" [62mm]	Ø1.46" [37mm]	250psi (17 bar)	0.29
AP3600	~3.37" [86mm]	~2.61" [66mm]	Ø2.12" [54mm]	3,000psi (207 bar)	0.29
AP3625	~3.34" [85mm]	2.92" [74mm]	2.38" [60mm]	3,000psi (207 bar)	0.29
AP3650	~3.34" [85mm]	~2.51" [64mm]	Ø1.88" [48mm]	3,000psi (207 bar)	0.29

TABLE 3. DIMENSION CONFIGURATION, 1/4 INCH FACE SEAL

Designator	2(E) / F	Designator	2(E) / F	Designator	2(E) / F
1	4.65" / 2.82"	2	4.69" / 2.77"	3	4.65" / 2.14"
9	4.69" / 2.26"	10	4.69" / 2.15"	11	4.53" / 2.33"
13	4.65" / 2.26"	14	4.78" / 3.35"	15	4.53" / 2.26"
21	4.25" / 3.56"	22	4.65" / 3.04"	23	4.65" / 2.70"
24	4.06" / 2.66"	25	4.42" / 2.66"	26	5.40" / 3.04"
27	5.59" / 3.68"	28	5.40" / 2.66"	29	4.65" / 2.33"
31	4.15" / 2.82"	32	5.52" / 2.70"	33	5.33" / 2.97"

- Table 3 dimensions are for DVD and DVN configurations, 1/4 inch face seal connections.
- Optional dimensions and connections available.
- 'G' standard dimension equals 1.39 inch for MV4 and FV4 connections.
- 'TW4' standard dimension is 0.50 inch extension from the face of the body.
- Configuration and dimension drawing available upon request.

TABLE 4. ORDERING INFORMATION

Series AP 3625/3550	S Material	M Surface Finish Options	DVD Monoblock Configuration	22 Dimension Options	FV4 TW4 FV4 ① ② ③ Connection	BB Options
Actuator Type V ₁ /V ₂ Refer to Tables 1 & 2	S = 316L SS Secondary Remelt	M = 10μ in. Ra V = 7μ in. Ra X = 5μ in. Ra	Monoblock Configuration Designator Refer to Table 1	Dimension Configuration. Refer to Table 3. (Optional dimensions available)	MV4 = 1/4" Face Seal Male FV4 = 1/4" Face Seal Female TW4 = 1/4" Tube Weld (Optional fittings available)	ET = Etched Flow Diagram - DVD only (For options check individual data sheets)